



basic education

Department:
Basic Education
REPUBLIC OF SOUTH AFRICA

**NATIONAL
SENIOR CERTIFICATE**

GRADE 12

TECHNICAL MATHEMATICS P2

EXEMPLAR 2018

MARKS: 150

TIME: 3 hours

This question paper consists of 13 pages and an information sheet of 2 pages.

INSTRUCTIONS AND INFORMATION

Read the following instructions carefully before answering the questions.

1. This question paper consists of 11 questions.
2. Answer ALL the questions.
3. Clearly show ALL calculations, diagrams, graphs, etc. that you used to determine the answers.
4. Answers only will NOT necessarily be awarded full marks.
5. If necessary, round off answers to TWO decimal places, unless stated otherwise.
6. Diagrams are NOT necessarily drawn to scale.
7. You may use an approved scientific calculator (non-programmable and non-graphical)
8. Write neatly and legibly.

QUESTION 1

The picture shows electric poles and wires.

Assume that an electrician is standing next to electric pole **A**. Two assistants, to the right and left of the electrician respectively, are standing next to electric poles **B** and **D**.

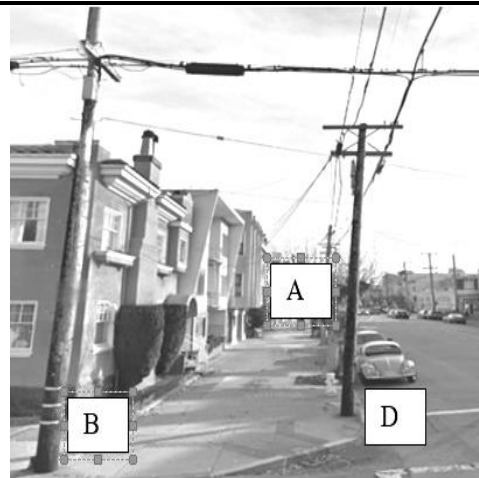

The diagram below, NOT drawn to scale, models the above situation in a Cartesian plane.

$\triangle ABD$ has vertices $A(1; 4)$, $B(-3; 1)$ and $D(5; -2)$. The angle formed by the x -axis and AE is α and the angle formed by the x -axis and AD is β .

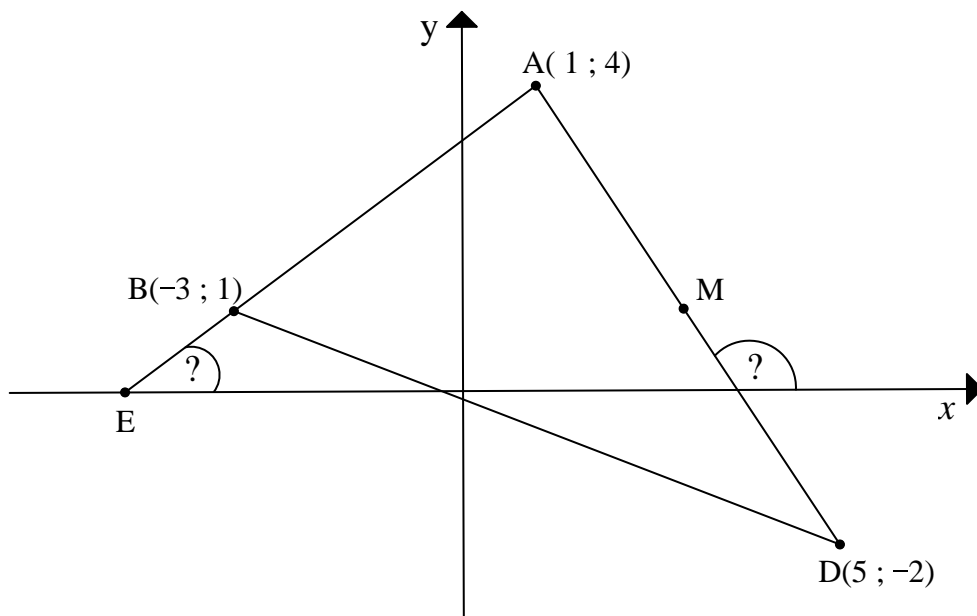

Determine:

- 1.1 The length of AD (leave your answer in simplified surd form) (3)
- 1.2 The coordinates of M , the midpoint of AD (2)
- 1.3 The equation of straight line MC (in the form $ax+by+c=0$) if $MC \parallel AB$. (5)
- 1.4 The size of α . (2)
- 1.5 The size of \hat{BAD} . (4)

[16]

QUESTION 2

- 2.1 In the diagram below, $O(0;0)$ is the centre of the circle and $F(10; -4)$ is a point on the circle. FH is the diameter of the circle and GH is a tangent to the circle at H .

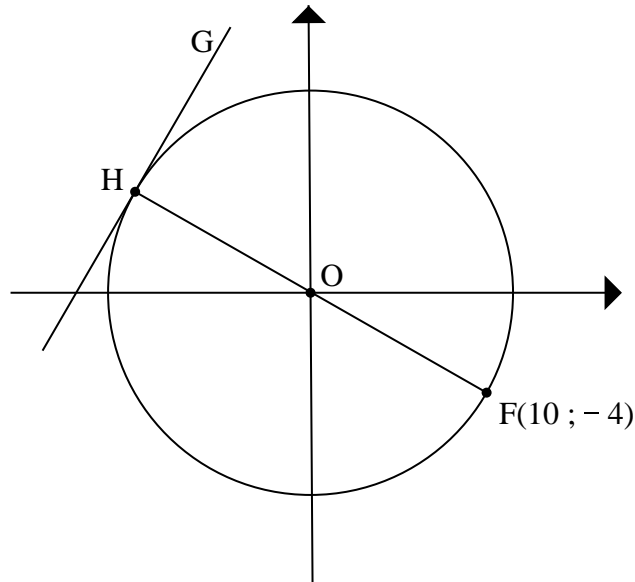

Determine:

- 2.1.1 The length of the radius of the circle (2)
- 2.1.2 The gradient of OH (2)
- 2.1.3 The equation of GH (4)
- 2.2 Sketch the graph defined by:

$$\frac{x^2}{16} + \frac{y^2}{10} = 1$$

Clearly show ALL the intercepts with the axes. (3)
[11]

QUESTION 3

- 3.1 In the diagram below, $P(12;-5)$ is a point in a Cartesian plane with origin $O(0;0)$. The reflex angle that is formed by OP with the positive x -axis is θ .

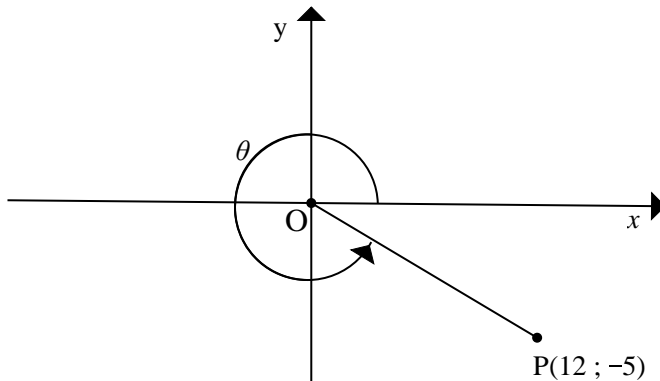

Determine, without using a calculator, the value of each of the following:

- 3.1.1 The length of OP (1)
- 3.1.2 $5 \cot \theta - 13 \cos \theta$ (3)
- 3.1.3 $\operatorname{cosec}^2 \theta - 1$ (2)
- 3.2 Determine the numerical value of $\sec(a-b)$ if $a = 2,695$ and $b = 1,112$. (3)
- [9]**

QUESTION 4

- 4.1 Simplify (without using a calculator) the following as a single trigonometrical ratio:

$$\frac{\sin(360^\circ - x) \cdot \cos(180^\circ - x) \cdot \tan 120^\circ}{\cos^2 x \cdot \sin \frac{5}{6} \pi} \quad (7)$$

- 4.2 Complete the following identity: $1 - \sin^2 3x = \dots\dots$ (1)
- 4.3 Prove the identity: $\tan x \cdot \sin x = \sec x - \cos x$ (4)
- 4.4 Solve for x : $\operatorname{cosec} 2x = 2,114$ for $2x \in [0^\circ; 180^\circ]$ (4)
- [16]**

QUESTION 5

The diagram below represents a person standing at point A on top of building AB which is 50 metres high. He observes 2 buses, C and D, that are on the same horizontal plane as B. The angle of elevation of A from C is 55° and the angle of elevation of A from D is 55° .

$\hat{CAD} = 65^\circ$

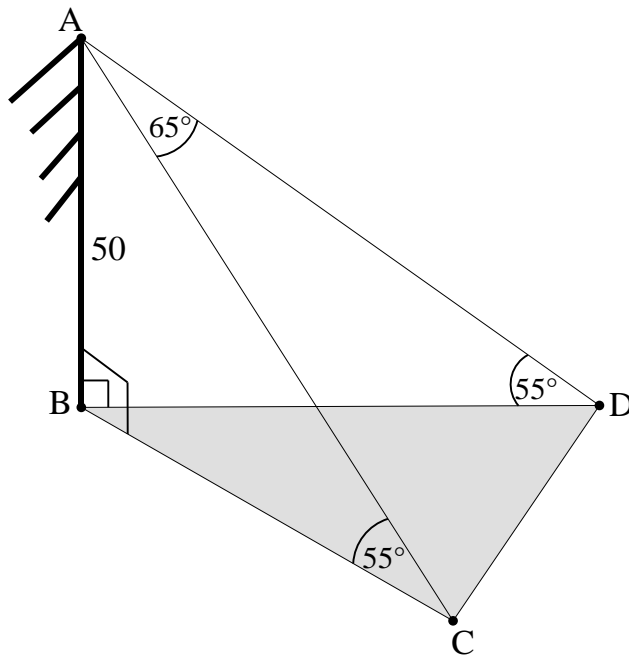

- 5.1 Calculate the length AC to the nearest metre. (3)
 - 5.2 Calculate the distance (to the nearest metre) between the two buses. (4)
 - 5.3 If the area of $\triangle BDC$ is 563 m^2 , calculate the size of \hat{BDC} . (6)
- [13]**

QUESTION 6

Given: $f(x) = 2 \sin x$ and $g(x) = \cos(x + 30^\circ)$ for $x \in [0^\circ; 360^\circ]$

- 6.1 Draw the graphs of f and g on the same set of axes. Clearly show the intercepts with the axes as well as the turning points of the graphs. (6)
 - 6.2 Write down the amplitude of f . (1)
 - 6.3 Determine the period of $g(x - 60^\circ)$. (1)
 - 6.4 For which value(s) of x is $g(x) < 0$? (2)
- [10]**

QUESTION 7

7.1 Complete the following theorem statement:

The angle between the tangent to a circle and the chord drawn from the point of contact is equal to ...

(1)

7.2 In the diagram below, PQ is the diameter of circle PQRS with centre M. TS is the tangent to the circle at point S.

$\hat{S}_1 = 38^\circ$ and $\hat{P}_1 = 17^\circ$

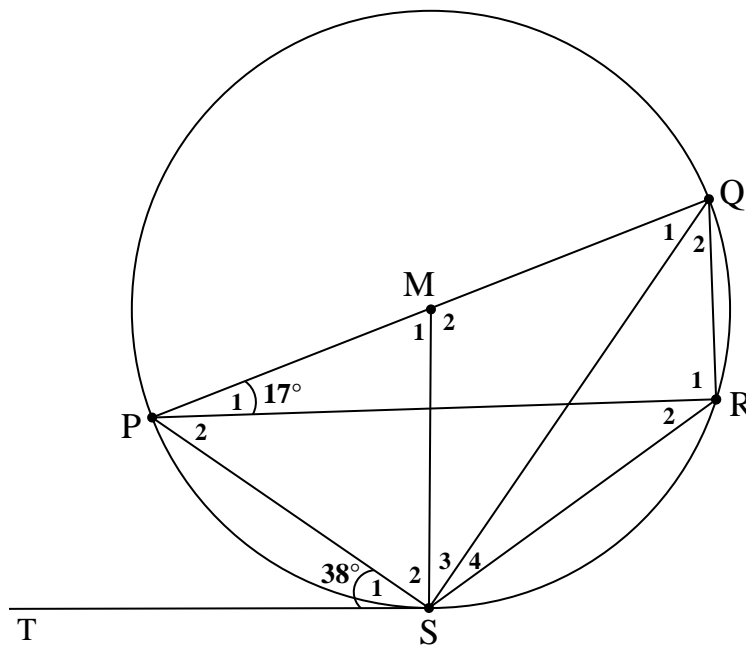

Determine, with reasons, the sizes of:

7.2.1 \hat{R}_2 (2)

7.2.2 \hat{M}_1 (2)

7.2.3 \hat{S}_2 (2)

7.2.4 \hat{Q}_2 (5)

7.2.5 Give a reason why PM is not parallel to SR. (1)

[13]

QUESTION 8

8.1 Complete the following theorem statement:

A line drawn parallel to one side of a triangle ... (1)

8.2 In the diagram $\triangle MNP$ with R on MP and T on MN is given such that $RT \parallel PN$.
S is a point on PN such that $TS \parallel MP$.

- MR = 10 units
- RP = 4 units
- MT = 8 units
- RT = 9 units
- TN = x units
- SN = y units

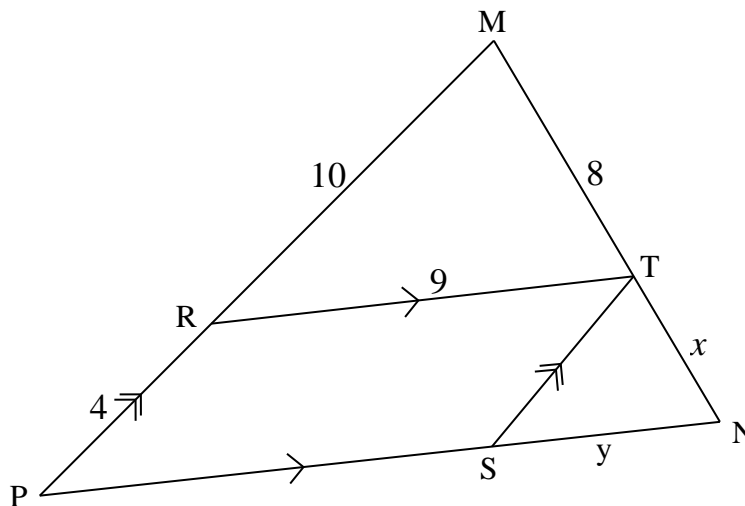

- 8.2.1 Calculate, stating reasons, the numerical value of x . (3)
- 8.2.2 What type of quadrilateral is RTSP? Give a reason for the answer. (2)
- 8.2.3 Hence calculate, stating reasons, the numerical value of y . (3)
- 8.2.4 Hence, show with calculations, that $\triangle MRT \parallel \triangle TSN$. (4)

[13]

QUESTION 9

In the diagram, HLKF is a cyclic quadrilateral. The chords HL and FK are produced to meet at M. The line through F, parallel to KL, meets MH produced at G.

- MK = 10 units
- KF = 20 units
- ML = 12 units
- LH = HG
- $\hat{M} = 20^\circ$
- $\hat{K}_1 = 104^\circ$

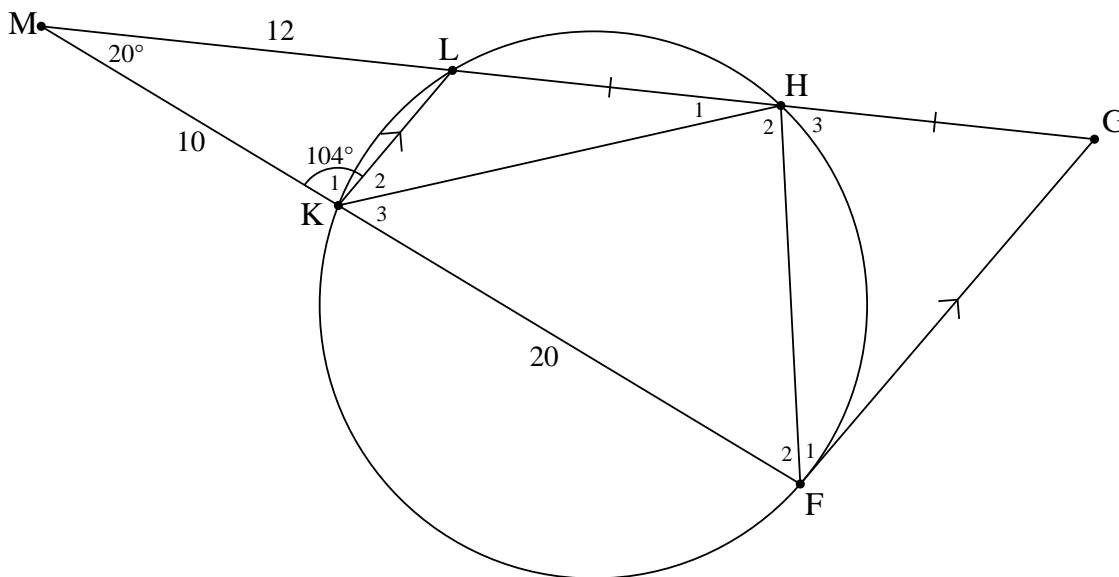

- 9.1 Name, with reasons, TWO other angles that are equal to \hat{K}_1 . (3)
 - 9.2 Determine the size of \hat{G} . (3)
 - 9.3 Use calculations to prove that:
 - 9.3.1 $MG = 36$ units (3)
 - 9.3.2 (a) $\triangle MFH \parallel \triangle MGF$ (3)
 - (b) Hence, complete: $\triangle MFH \parallel \triangle MGF \parallel \Delta \dots$ (1)
- [13]**

QUESTION 10

- 10.1 A circle with a diameter of 220 mm is divided by chord AB into two segments, as shown in the diagram below. The height of one segment is 60 mm.

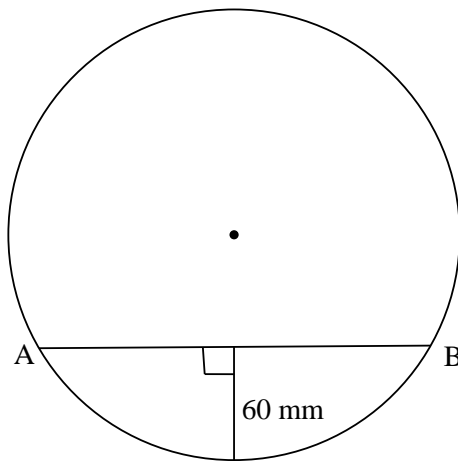

Calculate the length of chord AB.

(4)

- 10.2 A helicopter, as shown in the picture below, has rotating blades with a radius of 9 metres that rotate at 225 revolutions per minute.



Calculate the following for the rotating blades:

- 10.2.1 The circumferential velocity in metres per second

(4)

- 10.2.2 The angular velocity in radians per second

(3)

- 10.3 An engineer is installing two pulleys with centres, A and B, in a machine, as shown in the picture below. The two pulleys have radii of 50 cm and 20 cm respectively. The centres, A and B, of the pulleys are 120 cm apart and the length of the driving belt from K to L, which are points of contact, is 110 cm. It is further given that $\hat{KAB} = 70^\circ$ and reflex $\hat{KAD} = 220^\circ$.

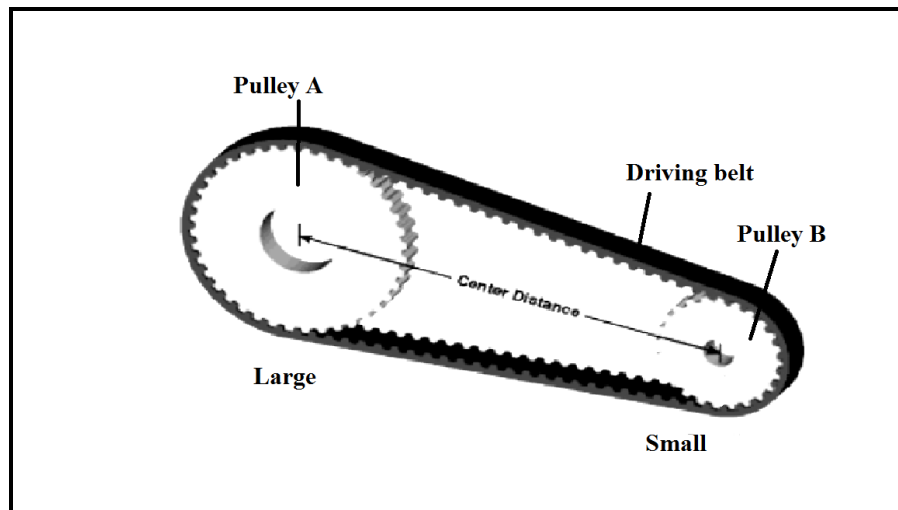

The diagram given below models the above situation:

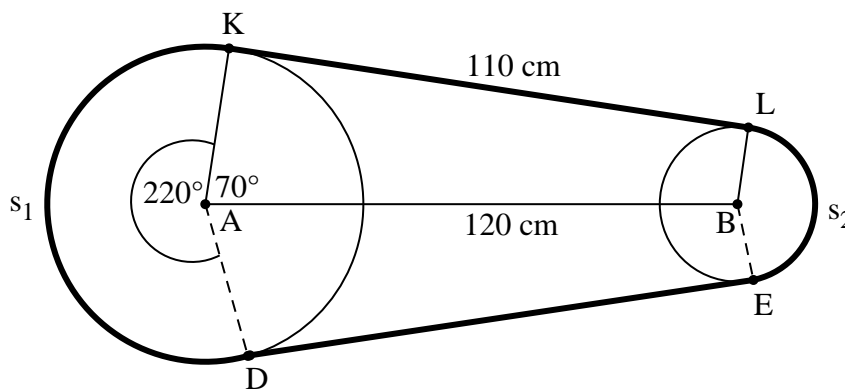

Where s_1 is the arc length of pulley A and s_2 is the arc length of pulley B.

- 10.3.1 Determine the magnitude of \hat{ABL} (HINT: $AK \parallel BL$) (2)
- 10.3.2 Determine the total length of the driving belt if arc length $s_2 = 48,8$ cm. (6)
- [19]

QUESTION 11

11.1 Hospital management is planning to have an additional water reservoir built. The TVET College students were asked to design a reservoir different from the existing one, as shown below. The students designed a reservoir which is a combination of a cube and a square-based pyramid. The diagrams below show the existing reservoir and the planned new reservoir.

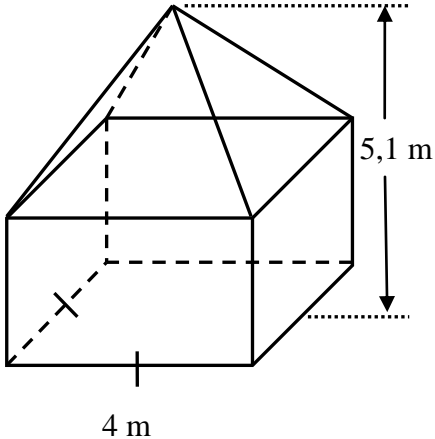
EXISTING RESERVOIR	RESERVOIR DESIGNED BY STUDENTS
	

The formulae below can be used to answer the questions that follow.

<p>Volume of pyramid = $\frac{1}{3} \times (\text{area of base}) \times (\text{height})$ Volume of a right prism = area of base \times height Area of a square = s^2 Area of $\Delta = \frac{1}{2} \times \text{base} \times \text{height}$</p>
--

- 11.1.1 Calculate the total volume of the reservoir designed by the students. (6)
- 11.1.2 Calculate the total exterior surface area (excluding the base) of the reservoir designed by the students. (5)
- 11.1.3 Hence, calculate the cost of the paint that will be needed to paint the exterior surface area of the reservoir designed by the students (excluding the base) if the cost of the paint is R30,50 per square metre. (2)

- 11.2 The irregular shape below has one straight side divided into 4 equal parts, 4 m apart. The ordinates dividing the parts are: 6,2 m ; y ; 5,1 m ; 4,9 m ; 2 m.

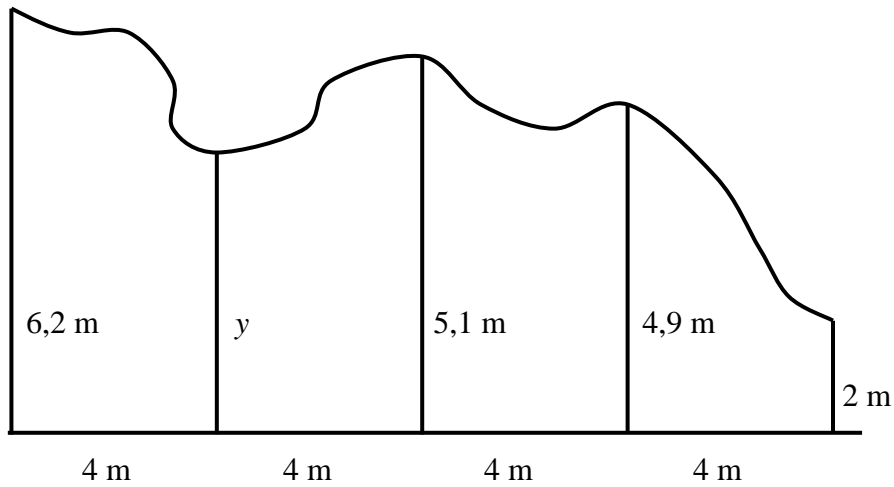

Calculate the value of y , using the mid-ordinate rule, if the area of the irregular shape is 72 m^2 .

(4)
[17]

TOTAL: 150

INFORMATION SHEET: TECHNICAL MATHEMATICS

$$x = \frac{-b \pm \sqrt{b^2 - 4ac}}{2a}$$

$$x = -\frac{b}{2a}$$

$$y = \frac{4ac - b^2}{4a}$$

$$a^x = b \Leftrightarrow x = \log_a b, \quad a > 0, a \neq 1 \text{ and } b > 0$$

$$A = P(1 + ni)$$

$$A = P(1 - ni)$$

$$A = P(1 - i)^n$$

$$A = P(1 + i)^n$$

$$i_{eff} = \left(1 + \frac{i}{m}\right)^m - 1$$

$$f'(x) = \lim_{h \rightarrow 0} \frac{f(x+h) - f(x)}{h}$$

$$\int x^n dx = \frac{x^{n+1}}{n+1} + C, \quad n \neq -1$$

$$\int \frac{1}{x} dx = \ln x + C, \quad x > 0$$

$$\int a^x dx = \frac{a^x}{\ln a} + C, \quad a > 0$$

$$d = \sqrt{(x_2 - x_1)^2 + (y_2 - y_1)^2}$$

$$M\left(\frac{x_1 + x_2}{2}, \frac{y_1 + y_2}{2}\right)$$

$$y = mx + c$$

$$y - y_1 = m(x - x_1)$$

$$m = \frac{y_2 - y_1}{x_2 - x_1}$$

$$m = \tan \theta$$

$$\frac{x^2}{a^2} + \frac{y^2}{b^2} = 1$$

In $\triangle ABC$: $\frac{a}{\sin A} = \frac{b}{\sin B} = \frac{c}{\sin C}$ $a^2 = b^2 + c^2 - 2bc \cdot \cos A$

area of $\triangle ABC = \frac{1}{2} ab \cdot \sin C$

$\sin^2 \theta + \cos^2 \theta = 1$ $1 + \tan^2 \theta = \sec^2 \theta$ $\cot^2 \theta + 1 = \operatorname{cosec}^2 \theta$

$\pi \text{ rad} = 180^\circ$

Angular velocity $= \omega = 2\pi n = 360^\circ n$ where n = rotation frequency

Circumferential velocity $= v = \pi Dn$ where D = diameter and n = rotation frequency

$s = r\theta$ where r = radius and θ = central angle in radians

Area of a sector $= \frac{rs}{2} = \frac{r^2\theta}{2}$ where r = radius, s = arc length and
 θ = central angle in radians

$4h^2 - 4dh + x^2 = 0$ where h = height of segment, d = diameter of circle and
 x = length of chord

$A_T = a(m_1 + m_2 + m_3 + \dots + m_n)$ where a = equal parts, $m_1 = \frac{o_1 + o_2}{2}$
and n = number of ordinates

OR

$A_T = a \left(\frac{o_1 + o_n}{2} + o_2 + o_3 + o_4 + \dots + o_{n-1} \right)$ where a = equal parts, $o_i = i^{\text{th}}$ ordinate and
 n = number of ordinates