



basic education

Department:
Basic Education
REPUBLIC OF SOUTH AFRICA

**NATIONAL
SENIOR CERTIFICATE
NASIONALE
SENIOR SERTIFIKAAT**

GRADE/GRAAD 12

**PHYSICAL SCIENCES: PHYSICS (P1)
FISIESE WETENSKAPPE: FISIKA (V1)**

NOVEMBER 2012

MEMORANDUM

MARKS/PUNTE: 150

**This memorandum consists of 12 pages.
*Hierdie memorandum bestaan uit 12 bladsye.***

SECTION A

QUESTION 1/VRAAG 1

- | | | |
|-----|---|------------|
| 1.1 | Frequency/ <i>Frekwensie</i> ✓ | (1) |
| 1.2 | Capacitor/ <i>Kapasitor</i> ✓ | (1) |
| 1.3 | Split ring commutator ✓
<i>Splitringkommutator</i> | (1) |
| 1.4 | Photons/ <i>Fotone</i> ✓ | (1) |
| 1.5 | <u>Relative velocity</u> / <u><i>Relatiewe snelheid</i></u> ✓ | (1) |
| | | [5] |

QUESTION 2/VRAAG 2

- | | | |
|------|------|-------------|
| 2.1 | D ✓✓ | (2) |
| 2.2 | C ✓✓ | (2) |
| 2.3 | D ✓✓ | (2) |
| 2.4 | D ✓✓ | (2) |
| 2.5 | A ✓✓ | (2) |
| 2.6 | A ✓✓ | (2) |
| 2.7 | D ✓✓ | (2) |
| 2.8 | C ✓✓ | (2) |
| 2.9 | C ✓✓ | (2) |
| 2.10 | A ✓✓ | (2) |
| | | [20] |

TOTAL SECTION A/TOTAAL AFDELING A: 25

SECTION B/AFDELING B

QUESTION 3/VRAAG 3

3.1 Downward/afwaarts ✓ (1)

3.2

3.2.1 **Upwards positive/Opwaarts positief:**

$$\begin{aligned}v_f &= v_i + a\Delta t \checkmark \\ &= 8 \checkmark + (-9,8)(4) \checkmark \\ &= -31,2 \text{ m}\cdot\text{s}^{-1} \\ \therefore v_f &= 31,2 \text{ m}\cdot\text{s}^{-1} \checkmark\end{aligned}$$

Downwards positive/Afwaarts positief:

$$\begin{aligned}v_f &= v_i + a\Delta t \checkmark \\ &= -8 \checkmark + (9,8)(4) \checkmark \\ \therefore v_f &= 31,2 \text{ m}\cdot\text{s}^{-1} \checkmark\end{aligned}$$
 (4)

3.2.2

OPTION 1/OPSIE 1
Upwards positive/Opwaarts positief:
$$\begin{aligned}\Delta y &= v_i\Delta t + \frac{1}{2}a\Delta t^2 \checkmark \\ &= (8)(4) \checkmark + \frac{1}{2}(-9,8)(4)^2 \checkmark \\ &= -46,4 \text{ m}\end{aligned}$$

↓

Height of balcony/Hoogte van balkon:
 $60 - 46,4 \checkmark = 13,6 \text{ m} \checkmark$

Downwards positive/Afwaarts positief:
$$\begin{aligned}\Delta y &= v_i\Delta t + \frac{1}{2}a\Delta t^2 \checkmark \\ &= (-8)(4) \checkmark + \frac{1}{2}(9,8)(4)^2 \checkmark \\ &= 46,4 \text{ m}\end{aligned}$$

↓

Height of balcony/Hoogte van balkon:
 $60 - 46,4 \checkmark = 13,6 \text{ m} \checkmark$

OPTION 2/OPSIE 2
Upwards positive/Opwaarts positief:
$$\begin{aligned}\Delta y &= v_i\Delta t + \frac{1}{2}a\Delta t^2 \checkmark \\ &= (27,13) \checkmark (6) \checkmark + \frac{1}{2}(-9,8)(6)^2 \checkmark \\ &= -13,62 \text{ m}\end{aligned}$$

Height of balcony/Hoogte van balkon:
 $= 13,62 \text{ m} \checkmark$

Downwards positive/Afwaarts positief:
$$\begin{aligned}\Delta y &= v_i\Delta t + \frac{1}{2}a\Delta t^2 \checkmark \\ &= (-27,13) \checkmark (6) \checkmark + \frac{1}{2}(9,8)(6)^2 \checkmark \\ &= 13,62 \text{ m}\end{aligned}$$

Height of balcony/Hoogte van balkon:
 $= 13,62 \text{ m} \checkmark$

(5)

3.3 **OPTION 1/OPSIE 1**
Upwards positive/Opwaarts positief:

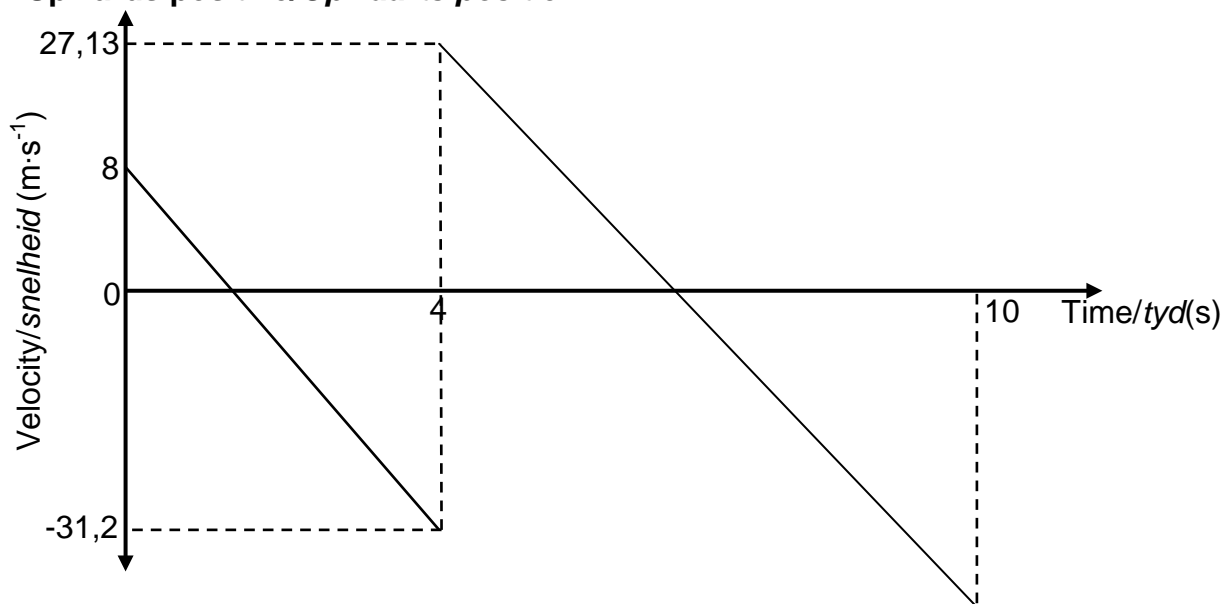

Criteria for graph/ <i>Kriteria vir grafiek:</i>	Marks/ <i>Punte</i>
Shape has two parallel lines with a gradient. <i>Vorm het twee ewewydige lyne met gradient.</i>	✓
First part of graph starts at $v = 8 \text{ m}\cdot\text{s}^{-1}$ at $t = 0 \text{ s}$ <i>Eerste deel van grafiek begin by $v = 8 \text{ m}\cdot\text{s}^{-1}$ by $t = 0 \text{ s}$.</i>	✓
Positive marking from QUESTION 3.2.1: <i>Positiewe nasien vanaf VRAAG 3.2.1:</i> First part of the graph extends below the x axis until $v = -31,2 \text{ m}\cdot\text{s}^{-1}$ at $t = 4 \text{ s}$. <i>Eerste deel van die grafiek verleng onder x-as tot $v = -31,2 \text{ m}\cdot\text{s}^{-1}$ by $t = 4 \text{ s}$.</i>	✓
Graph is discontinuous and object changes direction at 4 s. <i>Grafiek is nie kontinu nie en voorwerp verander van rigting by 4 s.</i>	✓
Second part of graph starts at $v = 27,13 \text{ m}\cdot\text{s}^{-1}$ at $t = 4 \text{ s}$. <i>Tweede deel van grafiek begin by $v = 27,13 \text{ m}\cdot\text{s}^{-1}$ by $t = 4 \text{ s}$.</i>	✓
Second part of graph extends below the x axis until $t = 10 \text{ s}$. <i>Tweede deel van grafiek verleng onder x-as tot $t = 10 \text{ s}$.</i>	✓

OPTION 2/OPSIE 2

Upwards negative/Opwaarts negatief:

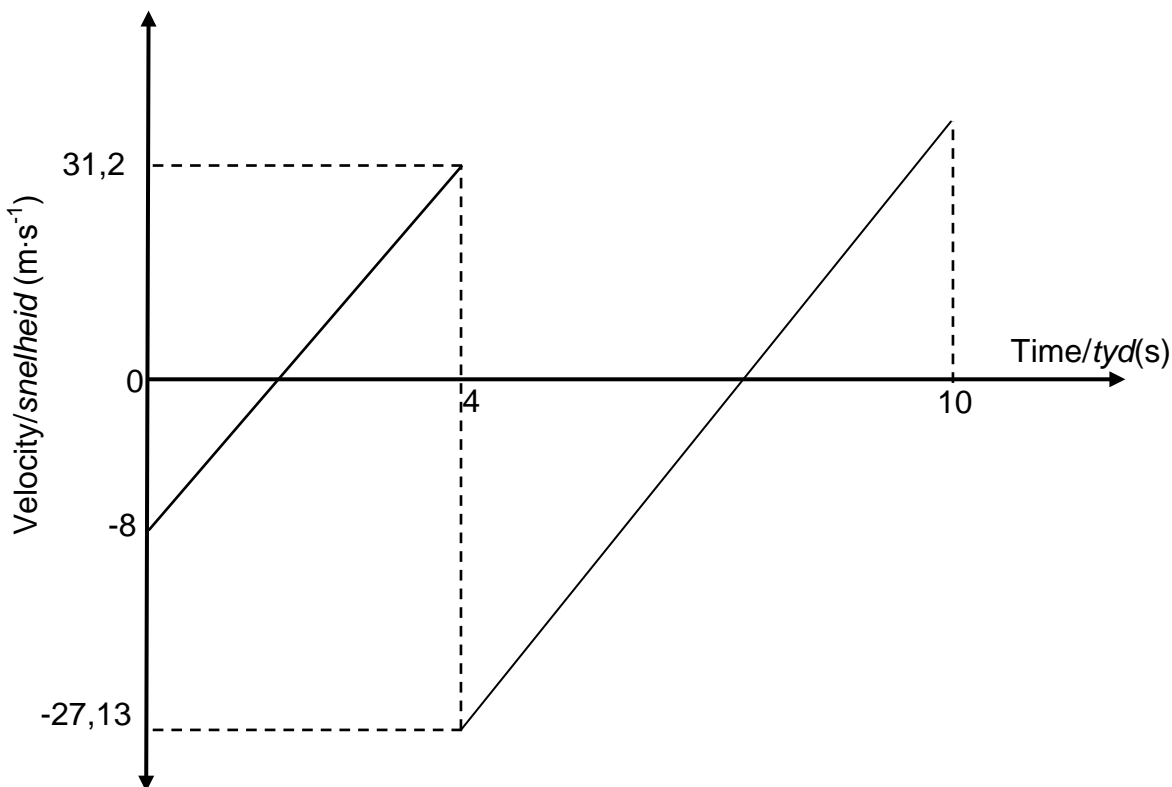

Criteria for graph/Kriteria vir grafiek:	Marks Punte
Correct shape as shown (two parallel lines). <i>Korrekte vorm soos aangetoon (twee ewewydige lyne).</i>	✓
First part of graph starts at $v = -8 \text{ m}\cdot\text{s}^{-1}$ at $t = 0 \text{ s}$ <i>Eerste deel van grafiek begin by $v = -8 \text{ m}\cdot\text{s}^{-1}$ by $t = 0 \text{ s}$</i>	✓
Positive marking from QUESTION 3.2.1. Positiewe nasien vanaf VRAAG 3.2.1. First part of the graph extends above the x axis until $v = 31,2 \text{ m}\cdot\text{s}^{-1}$ at $t = 4 \text{ s}$. <i>Eerste deel van die grafiek verleng bokant x-as tot $v = 31,2 \text{ m}\cdot\text{s}^{-1}$ by $t = 4 \text{ s}$.</i>	✓
Graph is discontinuous and object changes direction at 4 s. <i>Grafiek is nie kontinu en voorwerp verander van rigting by 4 s.</i>	✓
Second part of graph starts at $v = -27,13 \text{ m}\cdot\text{s}^{-1}$ at $t = 4 \text{ s}$. <i>Tweede deel van grafiek begin by $v = -27,13 \text{ m}\cdot\text{s}^{-1}$ by $t = 4 \text{ s}$.</i>	✓
Second part of graph extends above the x axis until $t = 10 \text{ s}$. <i>Tweede deel van grafiek verleng bokant x-as tot $t = 10 \text{ s}$.</i>	✓

(6)
[16]

QUESTION 4/VRAAG 4

4.1 $40 \text{ m}\cdot\text{s}^{-1}$ ✓ east/oos ✓ (2)

4.2 The total (linear) momentum remains constant/is conserved ✓
in an isolated/a closed system/the absence of external forces/ if the impulse of external forces is zero. ✓

*Die totale (liniêre) momentum bly konstant/behoue ✓
in 'n geïsoleerde sisteem/geslote sisteem/ die afwesigheid van eksterne kragte./ indien die impuls van eksterne kragte nul is. ✓* (2)

4.3 **East positive/Oos positief:**

$$\Sigma p_i = \Sigma p_f \checkmark$$
$$m(20) \checkmark + 2m(-20) \checkmark = (m + 2m)v_f \checkmark$$
$$\therefore v_f = -6,67 \text{ m}\cdot\text{s}^{-1}$$

$$\therefore v_f = 6,67 \text{ m}\cdot\text{s}^{-1} \checkmark \text{ west /wes } \checkmark$$

East negative/Oos negatief:

$$\Sigma p_i = \Sigma p_f \checkmark$$
$$m(-20) \checkmark + 2m(+20) \checkmark = (m + 2m)v_f \checkmark$$
$$\therefore v_f = 6,67 \text{ m}\cdot\text{s}^{-1} \checkmark \text{ west /wes } \checkmark$$

(6)

4.4

4.4.1 F ✓
Newton's Third Law of motion/*Newton se Derde Bewegingswet* ✓ (2)

4.4.2 $-\frac{1}{2} a$ / $\frac{1}{2} a$ ✓
(Same/*Dieselfe* F_{net}), $a \propto \frac{1}{m}$ ✓ (2)

4.4.3 Car driver ✓
(Car - driver system) have greater acceleration. ✓
(Car - driver system) have greater change in velocity /greater Δv . ✓

*Motorbestuurder ✓
(Motor -bestuurder sisteem) het groter versnelling. ✓
(Motor -bestuurder sisteem) het groter verandering in snelheid / groter Δv . ✓* (3)

[17]

QUESTION 5/VRAAG 5

5.1

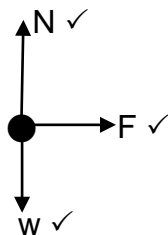

(3)

5.2 The net (total) work (done on an object) is equal to the change in kinetic energy (of the object.)

Die netto (totale) arbeid verrig (op 'n voorwerp) is gelyk aan die verandering in kinetiese energie (van die voorwerp).

(2)

5.3

5.3.1 $W_{\text{net}} = \Delta E_k / \Delta K$ ✓ **OR/OF** $F_{\text{net}} \Delta x \cos \theta = \frac{1}{2} m (v_f^2 - v_i^2)$

$F_{\text{net}} (1,02) \cos 180^\circ = \frac{1}{2} (1\,200) (0 - 20^2)$ ✓

$F_{\text{net}} = 235\,294,12 \text{ N}$ ✓ ($2,35 \times 10^5 \text{ N}$)

(4)

5.3.2

OPTION 1 / OPSIE 1

$F_{\text{net}} \Delta t = m \Delta v$ ✓

$\therefore (-235\,294,12) \Delta t = (1\,200) (0 - 20)$ ✓

$\therefore \Delta t = 0,1 \text{ s}$ ✓ (0,102 s)

OPTION 2 / OPSIE 2

$\Delta x = \left(\frac{v_i + v_f}{2} \right) \Delta t$ ✓

$1,02 = \left(\frac{20 + 0}{2} \right) \Delta t$ ✓

$\Delta t = 0,1 \text{ s}$ ✓

(4)

[13]

QUESTION 6/VRAAG 6

6.1 Frequency/*Frekwensie*

(1)

6.2 There is relative motion between the bird and the bird watcher.

Daar is relatiewe beweging tussen die voël en die voëlkyker nie.

(1)

6.3 0,2 m

(1)

6.4

6.4.1 $v = f \lambda$ ✓

$340 = f(0,2)$ ✓

$\therefore f = 1\,700 \text{ Hz}$ ✓

(3)

6.4.2

$f_L = \frac{v \pm v_L}{v \pm v_s} f_s$ **OR/OF** $f_L = \frac{v}{v - v_s} f_s$ ✓

$\therefore 1\,700 = \frac{340}{340 - v_s} (1\,650)$ ✓

$\therefore v_s = 10 \text{ m} \cdot \text{s}^{-1}$ ✓

(5)

[11]

QUESTION 7/VRAAG 7

7.1 Double slit/Dubbelspleet ✓ (1)

7.2 (Alternate) dark and bright/blue bands. ✓
Bright / blue bands of equal broadness (width). ✓
 (Afwissellende) donker en helder/blou bande. ✓
Helder / blou bande van gelyke breedte. ✓ (2)

7.3

7.3.1 $\tan \theta = \frac{\frac{1}{2} \text{ central band}}{\text{screen distance}} / \frac{\frac{1}{2} \text{ sentraleband}}{\text{skermafstand}}$
 $\therefore \tan \theta = \frac{\frac{1}{2}(0,22)}{1,4}$ ✓
 $\therefore \theta = 4,49^\circ$ ✓ (3)

7.3.2

OPTION 1/OPSIE 1:	OPTION 2/OPSIE 2:
$\sin \theta = \frac{m\lambda}{a}$ ✓	$\sin \theta = \frac{m\lambda}{a}$ ✓
$\sin 4,49^\circ = \frac{(1)(470 \times 10^{-9})}{a}$	$\sin (-4,49^\circ) = \frac{(-1)(470 \times 10^{-9})}{a}$
$\therefore a = 6 \times 10^{-6} \text{ m } \checkmark (6\ 003,67 \text{ nm})$	$\therefore a = 6 \times 10^{-6} \text{ m } \checkmark (6\ 003,67 \text{ nm})$

(5)

7.4 $\lambda_{\text{red light}} > \lambda_{\text{blue light}}$ ✓
 (Degree of) diffraction/sin $\theta / \theta \propto$ wavelength (λ) ✓
 $\lambda_{\text{rooilig}} > \lambda_{\text{bloulig}}$ ✓
 Diffraksie \propto golflengte (λ) ✓ (2)

[13]

QUESTION 8/VRAAG 8

8.1 $R = \frac{V}{I} \checkmark$
 $1\ 000 = \frac{12}{I} \checkmark$
 $\therefore I = 0,01\ A \checkmark$ (3)

8.2 $12\ V \checkmark$ (1)

8.3 $C = \frac{Q}{V} \checkmark$
 $120 \times 10^{-6} = \frac{Q}{12} \checkmark$
 $\therefore Q = 1,44 \times 10^{-3}\ C \checkmark$ (3)

8.4
 8.4.1 Decreases/*Verminder* \checkmark (1)

8.4.2 Increases/*Vermeerder* \checkmark (1)

8.5
 8.5.1

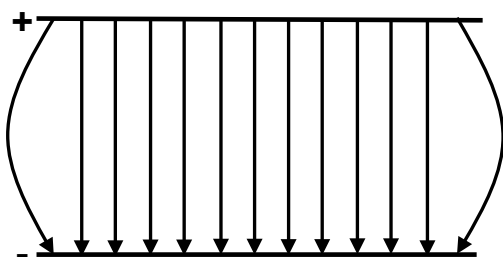

Criteria for sketch:/ <i>Kriteria vir skets:</i>	Marks/ <i>Punte</i>
Parallel lines equally spaced. <i>Parallele lyne eweredig gespaseer.</i>	\checkmark
Direction from positive plate towards negative plate. (Polarity of plates must be indicated) <i>Rigting vanaf positiewe plaat na negatiewe plaat. (Polariteit van plate moet aangedui word)</i>	\checkmark
Field curved at the ends of the plates. <i>Veld gekrom aan einde van die plate.</i>	\checkmark

(3)

8.5.2
 $E = \frac{V}{d} \checkmark$
 $= \frac{12}{12 \times 10^{-3}} \checkmark$
 $\therefore E = 1\ 000\ V \cdot m^{-1} \checkmark$ (3)

[15]

QUESTION 9/VRAAG 9

9.1

9.1.1
$$\frac{1}{R_p} = \frac{1}{R_1} + \frac{1}{R_2} \checkmark$$

$$= \frac{1}{60} + \frac{1}{60} \checkmark$$

$$\therefore R_p = 30 \Omega \checkmark$$
 (3)

9.1.2	<p><u>OPTION 1 / OPSIE 1</u> $R_{\text{ext}} = 30 + 25 = 55 \Omega \checkmark$ $\text{Emf}/\text{emk} = I(R + r) \checkmark$ $\therefore 12 \checkmark = I(55 + 1,5) \checkmark$ $\therefore I = 0,21 \text{ A} \checkmark$</p>	<p><u>OPTION 2 / OPSIE 2:</u> $R_{\text{tot}} = (30 + 25) \checkmark + 1,5 = 56,5 \Omega$ $V = IR \checkmark$ $12 \checkmark = I(56,5) \checkmark$ $\therefore I = 0,21 \text{ A} \checkmark$</p>	(5)
-------	--	--	-----

9.1.3	<p><u>OPTION 1/OPSIE 1</u> $V = IR \checkmark$ $= (0,21)(30) \checkmark$ $= 6,3 \text{ V} \checkmark$</p>	<p><u>OPTION 2/OPSIE 2</u> $V = IR \checkmark$ $= (0,105)(60) \checkmark$ $= 6,3 \text{ V} \checkmark$</p>	(3)
-------	--	---	-----

9.2

9.2.1 $1,5 \text{ V} \checkmark$ (1)

9.2.2
$$\text{gradient}/m = \frac{\Delta V}{\Delta I}$$

$$= \frac{0,65 - 1,5 \checkmark}{1,0 - 0 \checkmark}$$

$$= - 0,85 \Omega \checkmark$$
 (3)

9.2.3 Internal resistance $\checkmark \checkmark$
Interne weerstand (2)

9.2.4 Decreases/Verminder \checkmark
 When I increases/*Wanneer I toeneem:*
 "Lost volts"/ Ir increases./"Verlore volts"/*Ir neem toe.* \checkmark
 $V_{\text{ext}} = \text{emf} - Ir$ decreases. \checkmark / $V_{\text{ext}} = \text{emk} - Ir$ neem af. (3)
[20]

QUESTION 10/VRAAG 10

10.1 AC / WS ✓

(1)

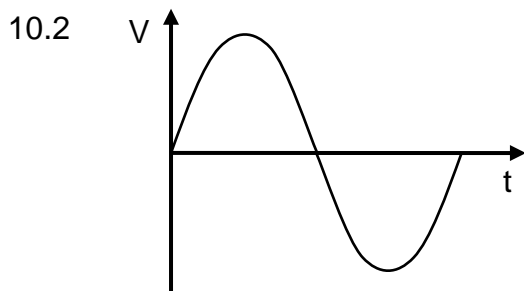

Criteria for graph/Kriteria vir grafiek:	Marks/Punte
Correct shape as shown; accept more than one cycle. <i>Korrekte vorm soos aangetoon; aanvaar meer as een siklus.</i>	✓✓
If no/wrong labels: minus 1 mark <i>Indien geen/verkeerde byskifte: minus 1 punt</i>	

(2)

10.3

OPTION 1/OPSIE 1	OPTION 2 / OPSIE 2
$V_{rms/wgk} = \frac{V_{max/maks}}{\sqrt{2}} \checkmark$ $= \frac{30 \times 10^3}{\sqrt{2}} \checkmark$ $= 2,12 \times 10^4 \text{ V}$ $P_{ave} = V_{rms} I_{rms} / P_{gem.} = V_{wgk} I_{wgk} \checkmark$ $4,45 \times 10^9 \checkmark = (2,12 \times 10^4) I_{rms/wgk}$ $\therefore I_{rms/wgk} = 2,10 \times 10^5 \text{ A} \checkmark$	$P_{ave} = V_{rms} I_{rms} / P_{gem.} = V_{wgk} I_{wgk}$ $P_{ave/gem.} = \frac{V_{max} I_{rms}}{\sqrt{2}} / \frac{V_{maks} I_{wgk}}{\sqrt{2}} \checkmark \checkmark$ $4,45 \times 10^9 \checkmark = \frac{(30 \times 10^3) I_{rms/wgk}}{\sqrt{2}} \checkmark$ $\therefore I_{rms/wgk} = 2,10 \times 10^5 \text{ A} \checkmark$

(5)

10.4 Less loss in (electrical) energy (as heat). ✓

Minder verlies aan (elektriese) energie (as hitte). ✓

(1)

[9]

QUESTION 11/VRAAG 11

- 11.1
- 11.1.1 Kinetic energy / *Kinetiese energie* (E_k) ✓ (1)
- 11.1.2 Frequency / *Frekwensie* ✓ (f) (1)
- 11.1.3 (Type of) metal ✓
(*Soort*) metaal ✓ (1)
- 11.2 The minimum frequency needed to emit electrons ✓
from (the surface of) a metal. ✓
Die minimum frekwensie benodig om elektrone vry te stel
vanaf (die oppervlak van) 'n metaal. (2)
- 11.3 9×10^{14} Hz ✓ (1)
- 11.4
- $E = W_0 + E_k$ } ✓ Any one / *Enige een*
 $hf = hf_0 + E_k$ }
- $(6,63 \times 10^{-34})(14 \times 10^{14}) \checkmark = (6,63 \times 10^{-34})(9 \times 10^{14}) \checkmark + E_k$
- $\therefore E_k = 3,32 \times 10^{-19} \text{ J} \checkmark (3,31 \times 10^{-19} \text{ J})$ (4)
- 11.5 Remains the same / *Bly dieselfde* ✓ (1)

[11]

TOTAL SECTION B/TOTAAL AFDELING B: 125
GRAND TOTAL/GROOTTOTAAL: 150