



basic education

Department:
Basic Education
REPUBLIC OF SOUTH AFRICA

NATIONAL SENIOR CERTIFICATE

GRADE 12

LIFE SCIENCES P1

VERSION 1 (NEW CONTENT) FOR FULL-TIME CANDIDATES

FEBRUARY/MARCH 2012

MARKS: 150

TIME: 2½ hours

This question paper consists of 15 pages.

INSTRUCTIONS AND INFORMATION

Read the following instructions carefully before answering the questions.

1. Answer ALL the questions.
2. Write ALL the answers in your ANSWER BOOK.
3. Start the answers to each question at the top of a NEW page.
4. Number the answers correctly according to the numbering system used in this question paper.
5. Present your answers according to the instructions of each question.
6. ALL drawings should be done in pencil and labelled in blue or black ink.
7. Draw diagrams or flow charts only when asked to do so.
8. The diagrams in this question paper are NOT necessarily drawn to scale.
9. Do NOT use graph paper.
10. You may use a non-programmable calculator, protractor and a compass.
11. Write neatly and legibly.

SECTION A**QUESTION 1**

1.1 Various options are provided as possible answers to the following questions. Choose the correct answer and write only the letter (A to D) next to the question number (1.1.1 to 1.1.10) in your ANSWER BOOK, for example 1.1.11 D.

1.1.1 Genes only code for ...

- A starch.
- B proteins.
- C glucose.
- D fats.

1.1.2 The wings of a butterfly and the wings of a bird are examples of ...

- A homologous structures.
- B vestigial structures.
- C analogous structures.
- D common ancestry.

1.1.3 Which ONE of the following is an acceptable explanation based on Darwin's theory of evolution?

- A Humans evolved from apes
- B A mother who had her appendix removed will give birth to children without an appendix
- C An increasing number of TB-causing bacteria are resistant to antibiotics because those that are resistant are able to survive and reproduce
- D Giraffes have long necks because the previous generation stretched their necks to reach the leaves in tall trees

1.1.4 As DNA was extracted from cells of *E. coli* it was analysed for its nitrogenous base composition. It was found that 38% of the bases are cytosine. What percentage of the bases are adenine?

- A 12
- B 24
- C 38
- D 62

1.1.5 Below is a list of fossils discovered in South Africa.

1. Mrs Ples
2. Taung child
3. Little foot
4. Karabo

Which of the fossils above are classified in the genus *Australopithecus*?

- A 1, 2 and 3 only
B 1, 2, 3 and 4
C 2, 3 and 4 only
D 1, 3 and 4 only

1.1.6 A mother has blood group B and a father blood group O. They have three children and an adopted child. The blood groups of the children are represented in the table below.

CHILDREN	BLOOD GROUPS
Sindy	AB
Nobubele	B
Kenny	O
Gabriele	B

Which child is adopted?

- A Sindy
B Nobubele
C Gabriele
D Kenny

QUESTIONS 1.1.7 to 1.1.9 are based on the diagrammatic representation below of a part of two different nucleic acid molecules found in the cells of organisms during a stage in the process of protein synthesis.

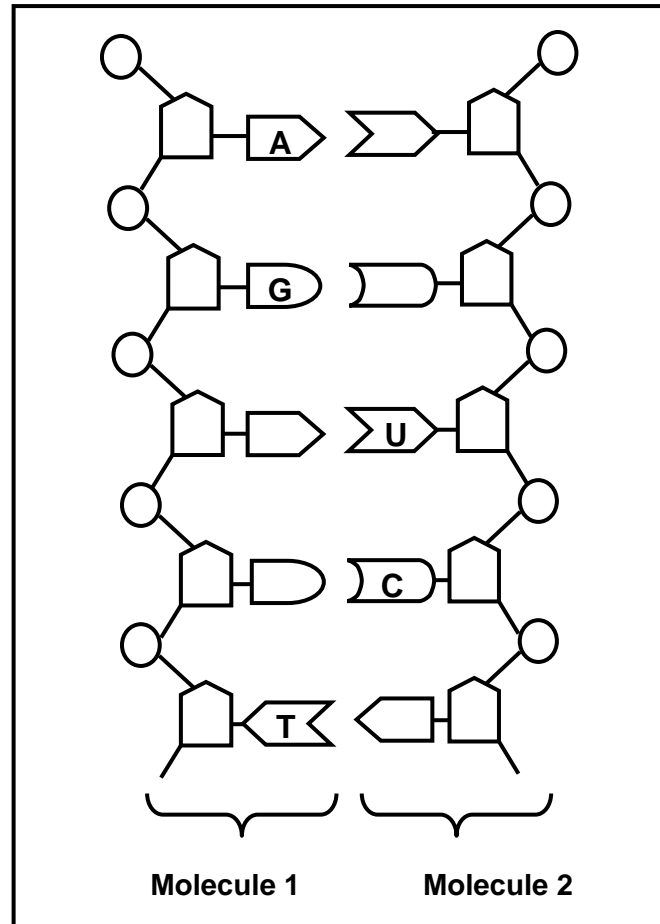

1.1.7 The diagram above illustrates the process of ...

- A replication.
- B transcription.
- C translation.
- D mutation.

1.1.8 The process illustrated above occurs in the ...

- A cytoplasm.
- B centrosome.
- C ribosome.
- D nucleus.

1.1.9 An observable difference between molecule 1 and molecule 2 is that ...

- A molecule 1 is double stranded and molecule 2 is single stranded.
- B molecule 1 contains deoxyribose sugars and molecule 2 contains ribose sugars.
- C molecule 1 has thymine and molecule 2 has uracil.
- D molecule 1 is longer than molecule 2.

1.1.10 The mRNA sequence from a portion of a DNA template GATCAA is ...

- A CTAGTT.
- B CUAGUU.
- C AGCTGG.
- D AGCUGG.

(10 x 2) **(20)**

1.2 Give the correct **biological term** for each of the following descriptions. Write only the term next to the question number (1.2.1 to 1.2.9) in your ANSWER BOOK.

1.2.1 An allele that is not shown/expressed in the phenotype when found in the heterozygous condition

1.2.2 Chromosomes other than the sex chromosomes

1.2.3 The production of genetically identical organisms using biotechnology

1.2.4 More than two haploid sets of chromosomes found in the cells of an organism

1.2.5 The transfer of a selected gene from one organism to another

1.2.6 A variable that is manipulated during an investigation

1.2.7 All the genes of a particular species

1.2.8 The position of a gene on a chromosome

1.2.9 The complete disappearance of a species from Earth **(9)**

- 1.3 Indicate whether each of the statements in COLUMN I applies to **A ONLY**, **B ONLY**, **BOTH A AND B** or **NONE** of the items in COLUMN II. Write **A only**, **B only**, **both A and B**, or **none** next to the question number (1.3.1 to 1.3.6) in the ANSWER BOOK.

COLUMN I		COLUMN II
1.3.1	The study of the past and present distribution of individual species as evidence for evolution	A: Palaeontology B: Biogeography
1.3.2	The evidence used to support the 'Out of Africa' hypothesis by tracing the maternal lineage	A: Y chromosome B: Mitochondrial DNA
1.3.3	Inheritance of the disorder linked to a sex chromosome	A: Colour blindness B: Sickle cell anaemia
1.3.4	First <i>Homo</i> species to have migrated out of Africa	A: <i>Homo habilis</i> B: <i>Homo sapiens</i>
1.3.5	Natural selection as an explanation for evolution	A: Alfred Wallace B: Charles Darwin
1.3.6	Organisms have an inherent/internal drive to change	A: Lamarck B: Wallace

(6 x 2) (12)

1.4 The diagram below represents a cladogram (phylogenetic tree) showing primate evolution. The letters, **A** to **E**, indicate the characteristics which are shared by the different species of primates which follow the letter. The point where various species of primates differ from each other is indicated by the branching-off/split into new species.

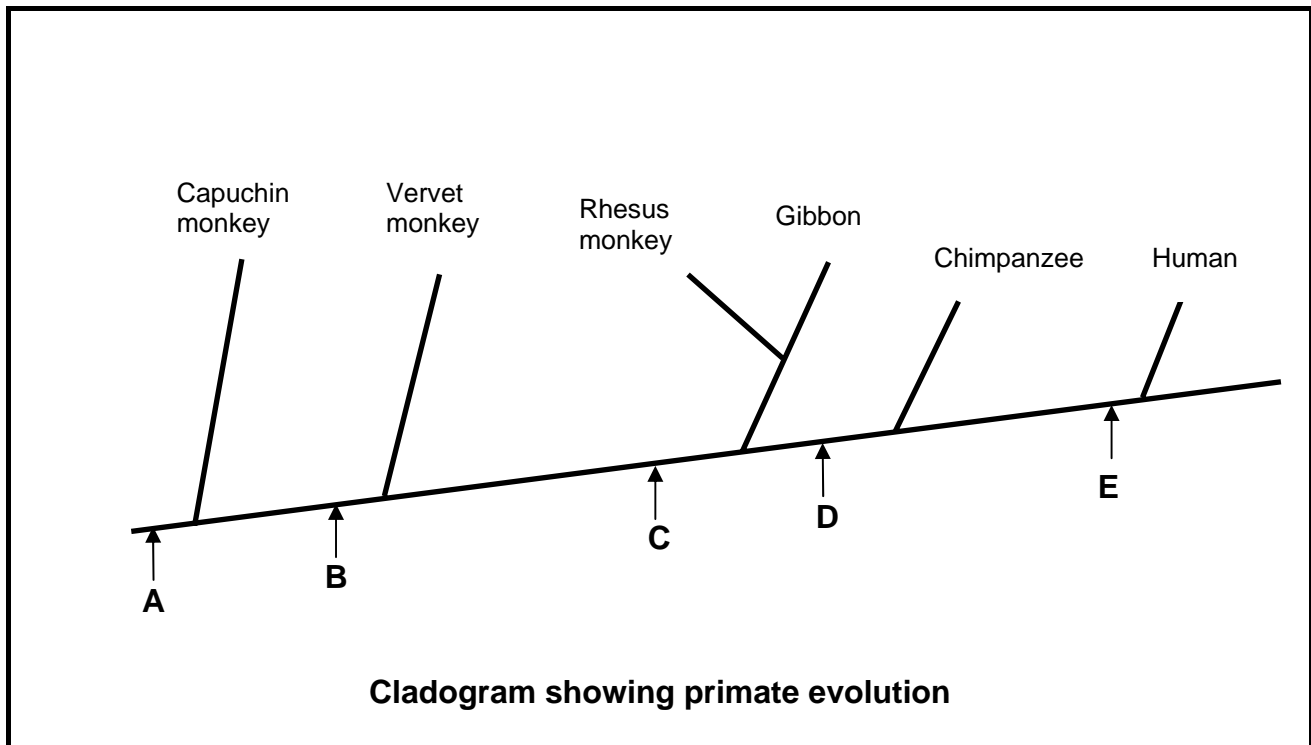

- 1.4.1 Which LETTER represents a common characteristic of all primates? (1)
- 1.4.2 List THREE structural characteristics represented by the LETTER named in QUESTION 1.4.1. (3)
- 1.4.3 Which organism is most similar to the chimpanzee? (1)
- 1.4.4 Name any TWO structural characteristics of the skull that make the organism named in QUESTION 1.4.3 different from the chimpanzee. (2)
- 1.4.5 Write down the names of the organisms that display the characteristic **C** but not characteristics **D** and **E**. (2)

(9)

TOTAL SECTION A: 50

SECTION B

QUESTION 2

2.1 Study the diagrams below which illustrate some phases of meiosis I.

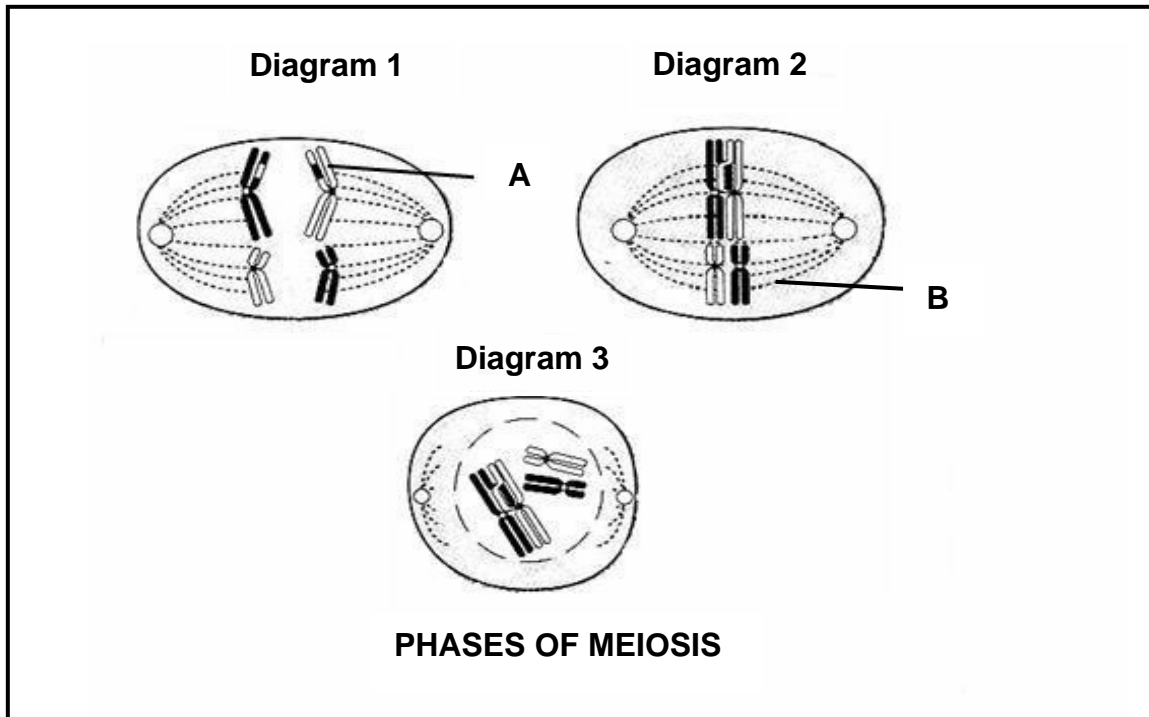

- 2.1.1 Label parts **A** and **B** respectively. (2)
 - 2.1.2 The diagrams above are not placed in the correct sequence. Use the diagram numbers to write down the correct sequence in which part of the process of meiosis I takes place. (2)
 - 2.1.3 Give TWO observable reasons why the phases in the diagram are part of meiosis I. (2)
- (6)**

2.2 The karyotype below is that of a male person with a genetic disorder called Klinefelter syndrome.

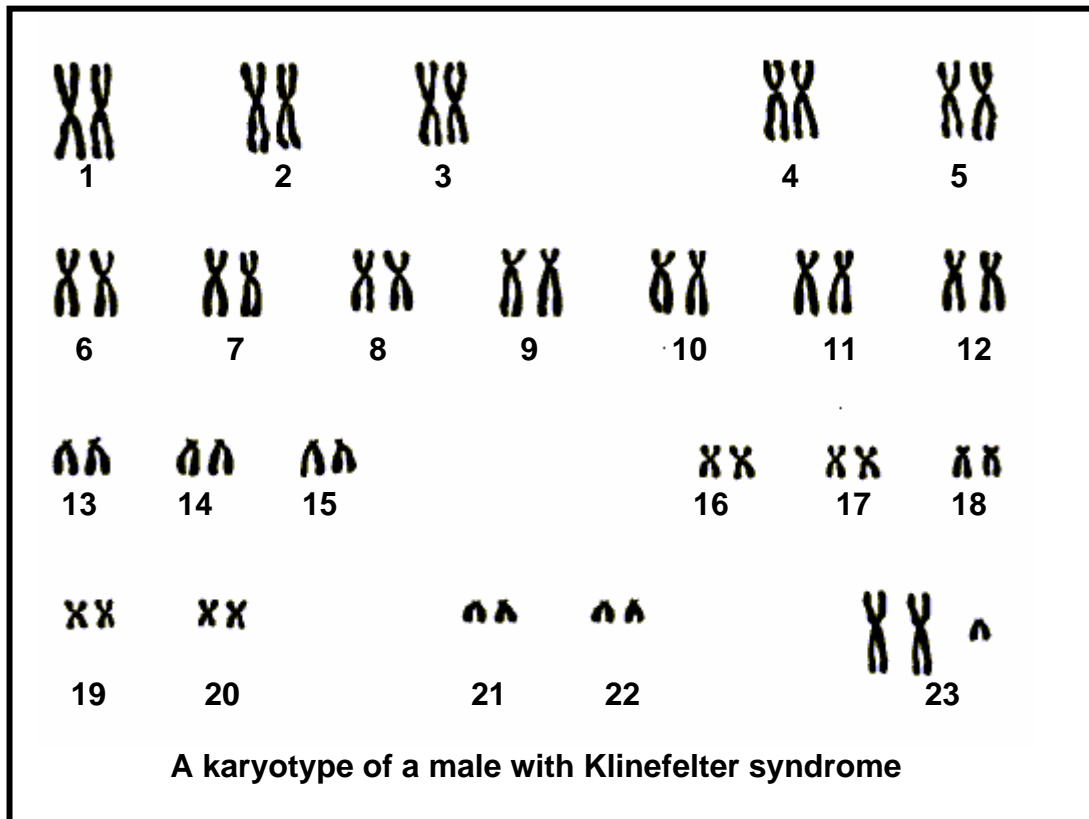

2.2.1 State ONE visible difference between the karyotype above and the karyotype of a normal male. (2)

2.2.2 Use your knowledge of meiosis to explain how Klinefelter syndrome could have resulted. (6)
(8)

2.3 A boy's mother had a patch of white hair called a 'white forelock' which is caused by a dominant allele **H**. The mother is heterozygous for this trait. His father does not have a 'white forelock'. The symbol for the recessive allele is **h**.

Represent a genetic cross to determine the possible genotypes and phenotypes of the children. (6)

2.4 Study the pedigree diagram below which shows the inheritance of flower colour in a certain plant over three generations.

Use the following symbols for the contrasting alleles:

W – for white colour

R – for red colour

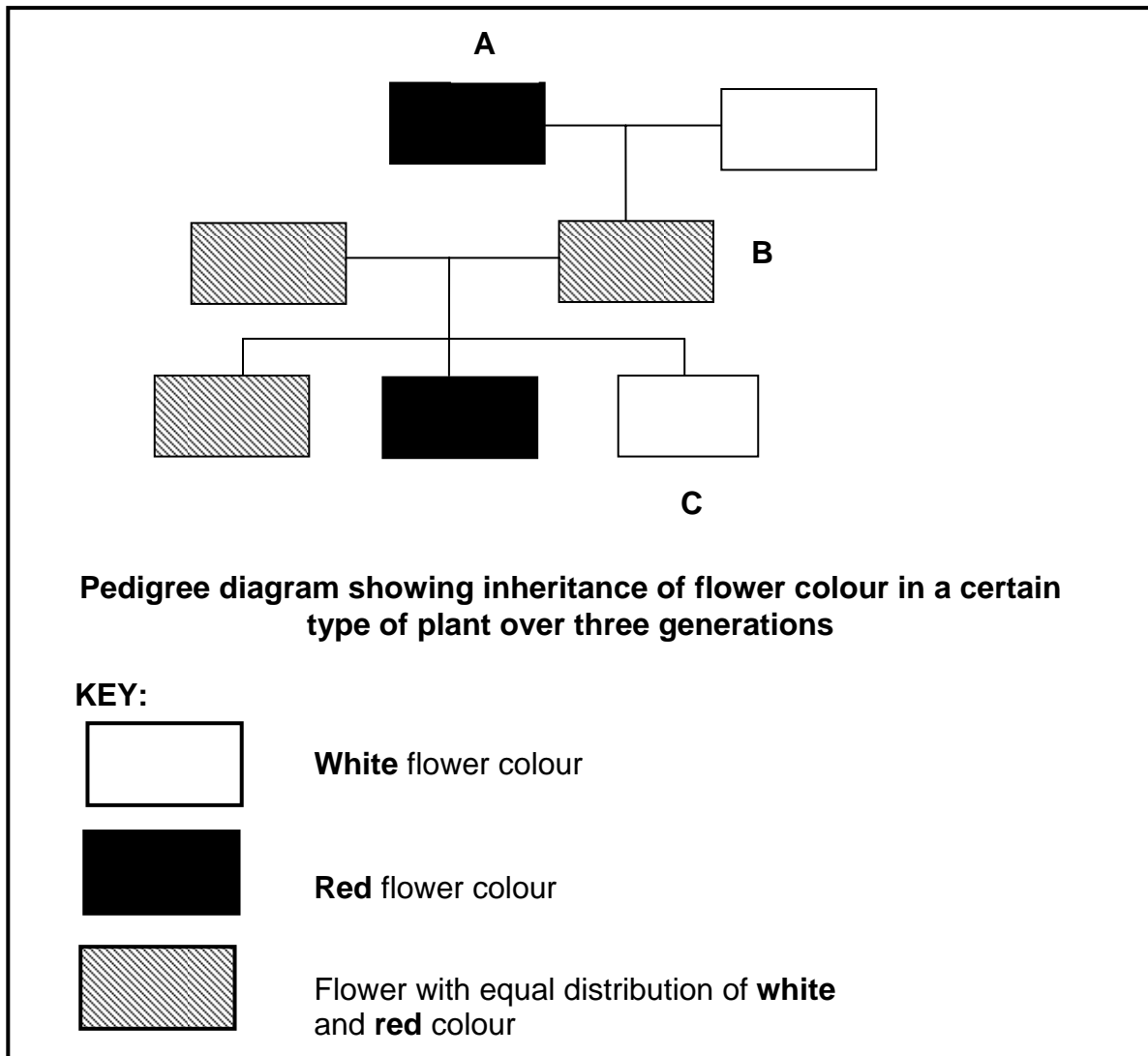

2.4.1 Name the type of inheritance shown in the pedigree diagram above. (1)

2.4.2 Explain your answer to QUESTION 2.4.1. (3)

2.4.3 Use the symbols **R** and **W** and write down the genotypes of each of the following flowers:

- (a) A
- (b) B
- (c) C

(3 x 2) (6)
(10)
[30]

QUESTION 3

- 3.1 A young couple wants to have a child, but they are aware of a serious genetic disorder in one of their families that could be carried through to their offspring.

In this case state:

- 3.1.1 ONE advantage of DNA testing (1)
- 3.1.2 THREE benefits of genetic counselling (3)
(4)
- 3.2 State TWO ways in which DNA profiling can be used to our advantage. (2)
- 3.3 Tabulate the structural differences between australopithecines, such as *Australopithecus sediba*, and humans by referring to the size of the skeleton, cranium and the chin. (7)
- 3.4 Read the passage below and then answer the questions that follow.

All types of domestic dogs are capable of interbreeding to produce puppies, which will eventually be capable of interbreeding with any other domestic dog.

The first dog evolved from a population of wolves. It is thought that wolves that were tamer than usual 'adopted' humans in order to scavenge food from refuse dumps near human settlements.

Although wolves look very similar to some breeds of domestic dogs, wolves and domestic dogs cannot interbreed.

- 3.4.1 Explain why all breeds of domestic dogs belong to the same species. (2)
- 3.4.2 Describe how a population of wolves may have undergone speciation to form the first population of dogs. (6)
- 3.4.3 Describe how artificial selection led to different breeds of domestic dogs. (2)
(10)

- 3.5 A group of learners from a school decided to do an investigation, using scientific literature, on the evidence presented by fossils to support the theory of evolution.

They formulated the following hypothesis:

'First appearance of fossils of single-cell/simple organisms are found in the oldest layers of rock'

A summary of their research from the scientific literature is shown in the table below.

ERA	GEOLOGICAL TIMESCALE (MILLION YEARS AGO)	MAJOR EVENTS IN THE HISTORY OF LIFE
Cenozoic	65–present	Appearance of <i>Homo</i> species Flowering plants, insects, birds and mammals became dominant
Mesozoic	240–65	Origin of flowering plants and mammals Dinosaurs, insects, fishes became dominant
Palaeozoic	570–240	Origin of reptiles, early fishes, insects and spore bearing plants which became dominant Origin of simple marine invertebrates and animals with hard parts
Cryptozoic	4 600–570 (Pre-Cambrian)	Origin of protists (unicellular organisms) Origin of photosynthetic bacteria

- 3.5.1 According to the results in the table above, will the learners accept or reject their hypothesis? (1)
- 3.5.2 Explain your answer to QUESTION 3.5.1. (2)
- 3.5.3 Explain the implications to the evolution theory if fossils of dinosaurs from the early Pre-Cambrian period were found. (2)
- 3.5.4 Explain why the invertebrates might have appeared earlier than our fossil record currently shows. (2)
- (7)**
[30]

TOTAL SECTION B: 60

SECTION C**QUESTION 4**

- 4.1 The table below shows the percentage distribution of blood groups in a province in South Africa.

BLOOD GROUPS			
A	B	AB	O
35	15	10	40

- 4.1.1 How many genes control the blood groups shown above? (1)
- 4.1.2 Explain how it is genetically possible to have four blood groups in a population. (2)
- 4.1.3 Draw a pie chart using the information in the table above. Show ALL calculations. (8)
(11)
- 4.2 Researchers observed that the height of a particular plant (*Achillea millefolium*) found at different altitudes varied.

They carried out the following procedure:

- 30 seeds of these plants were collected at each of four different altitudes.
- Each group of 30 seeds were then grown under the same environmental conditions in a greenhouse.
- The height of each plant was measured and the average for each group was calculated.
- The average height of each group was recorded next to the altitude at which the seeds were collected.

The following results were obtained:

ALTITUDE (m)	AVERAGE HEIGHT OF PLANTS (cm)
1 000	75
1 500	50
2 000	35
2 500	20

- 4.2.1 State a conclusion from the above investigation. (3)
- 4.2.2 Describe TWO things that the researchers did which ensured the validity of the procedure. (2)

4.2.3 In terms of natural selection, explain why the average height of the plants at 2 500 m is different from the average height of the plants at lower altitudes. (4)
(9)

4.3 Describe how point mutations, frame-shift mutations and meiosis contribute to genetic variation. (17)
Synthesis: (3)
(20)

NOTE: NO marks will be awarded for answers in the form of flow charts or diagrams.

TOTAL SECTION C: 40
GRAND TOTAL: 150