



basic education

Department:
Basic Education
REPUBLIC OF SOUTH AFRICA

**NATIONAL
SENIOR CERTIFICATE**

GRADE 12

PHYSICAL SCIENCES: PHYSICS (P1)

NOVEMBER 2013

MARKS: 150

TIME: 3 hours

This question paper consists of 15 pages and 3 data sheets.

INSTRUCTIONS AND INFORMATION

1. Write your centre number and examination number in the appropriate spaces on the ANSWER BOOK.
2. Answer ALL the questions in the ANSWER BOOK.
3. This question paper consists of TWO sections:

SECTION A (25)
SECTION B (125)
4. You may use a non-programmable calculator.
5. You may use appropriate mathematical instruments.
6. Number the answers correctly according to the numbering system used in this question paper.
7. YOU ARE ADVISED TO USE THE ATTACHED DATA SHEETS.
8. Give brief motivations, discussions, et cetera where required.
9. Round off your final numerical answers to a minimum of TWO decimal places.

SECTION A**QUESTION 1: ONE-WORD ITEMS**

Give ONE word/term for each of the following descriptions. Write only the word/term next to the question number (1.1–1.5) in the ANSWER BOOK.

- 1.1 The rate of change of velocity (1)
- 1.2 The distance between two consecutive points in phase on a wave (1)
- 1.3 A region of space in which an electric charge experiences an electrostatic force (1)
- 1.4 The type of electromagnetic wave with the shortest wavelength (1)
- 1.5 The minimum frequency of light needed to remove an electron from the surface of a metal (1)
- [5]**

QUESTION 2: MULTIPLE-CHOICE QUESTIONS

Four options are provided as possible answers to the following questions. Each question has only ONE correct answer. Write only the letter (A–D) next to the question number (2.1–2.10) in the ANSWER BOOK.

- 2.1 Which ONE of the following physical quantities is equal to the product of force and constant velocity?
- A Work
- B Power
- C Energy
- D Acceleration (2)
- 2.2 A 30 kg iron sphere and a 10 kg aluminium sphere with the same diameter fall freely from the roof of a tall building. Ignore the effects of friction.
- When the spheres are 5 m above the ground, they have the same ...
- A momentum.
- B acceleration.
- C kinetic energy.
- D potential energy. (2)

- 2.3 The free-body diagram below shows the relative magnitudes and directions of all the forces acting on an object moving horizontally in an easterly direction.

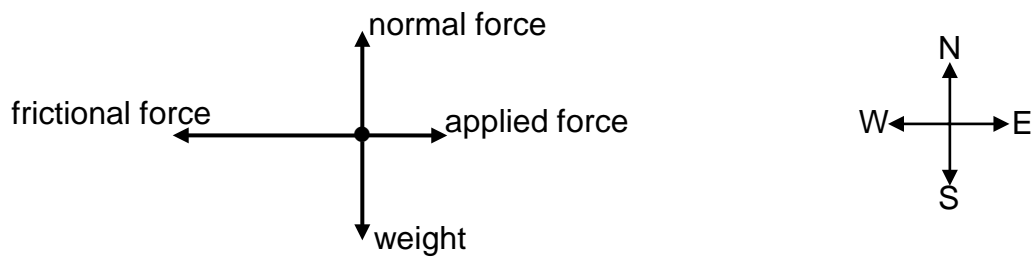

The kinetic energy of the object ...

- A is zero.
- B increases.
- C decreases.
- D remains constant. (2)
- 2.4 The hooter of a vehicle travelling at constant speed towards a stationary observer, produces sound waves of frequency 400 Hz. Ignore the effects of wind.
- Which ONE of the following frequencies, in hertz, is most likely to be heard by the observer?
- A 400
- B 350
- C 380
- D 480 (2)
- 2.5 When two waves meet at a point, the amplitude of the resultant wave is the algebraic sum of the amplitudes of the individual waves.
- This principle is known as ...
- A dispersion.
- B the Doppler effect.
- C superposition.
- D Huygens' principle. (2)

- 2.6 A parallel plate capacitor, **X**, with a vacuum between its plates is connected in a circuit as shown below. When fully charged, the charge stored on its plates is equal to Q .

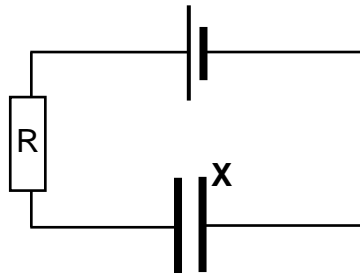

Capacitor **X** is now replaced with a similar capacitor, **Y**, with the same dimensions but with paper between its plates. When fully charged, the charge stored on the plates of capacitor **Y** is ...

- A zero.
 B equal to Q .
 C larger than Q .
 D smaller than Q . (2)

- 2.7 Which ONE of the following graphs best represents the relationship between the electrical power and the current in a given ohmic conductor?

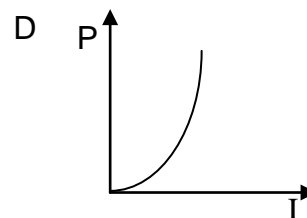
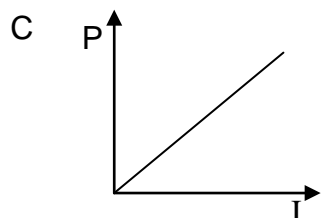
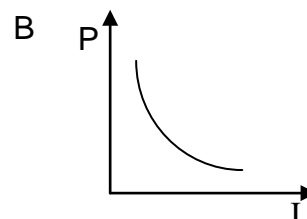
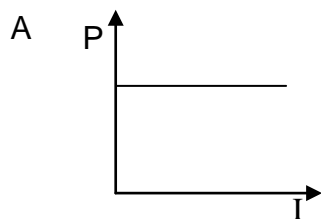

(2)

- 2.8 In a vacuum, all electromagnetic waves have the same ...

- A energy.
 B speed.
 C frequency.
 D wavelength. (2)

- 2.9 In the sketch below, a conductor carrying conventional current, I , is placed in a magnetic field.

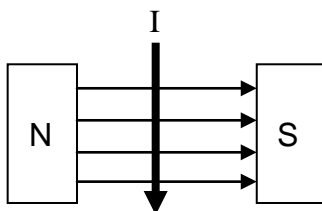

Which ONE of the following best describes the direction of the magnetic force experienced by the conductor?

- A Parallel to the direction of the magnetic field
 - B Opposite to the direction of the magnetic field
 - C Into the page perpendicular to the direction of the magnetic field
 - D Out of the page perpendicular to the direction of the magnetic field (2)
- 2.10 An atom in its ground state absorbs energy E and is excited to a higher energy state. When the atom returns to the ground state, a photon with energy ...
- A E is absorbed.
 - B E is released.
 - C less than E is released.
 - D less than E is absorbed. (2)

[20]

TOTAL SECTION A: 25

SECTION B**INSTRUCTIONS AND INFORMATION**

1. Start EACH question on a NEW page.
2. Leave ONE line between two subquestions, for example between QUESTION 3.1 and QUESTION 3.2.
3. Show the formulae and substitutions in ALL calculations.
4. Round off your final numerical answers to a minimum of TWO decimal places.

QUESTION 3 (Start on a new page.)

A ball of mass 0,15 kg is thrown vertically downwards from the top of a building to a concrete floor below. The ball bounces off the floor. The velocity versus time graph below shows the motion of the ball. Ignore the effects of air friction. TAKE DOWNWARD MOTION AS POSITIVE.

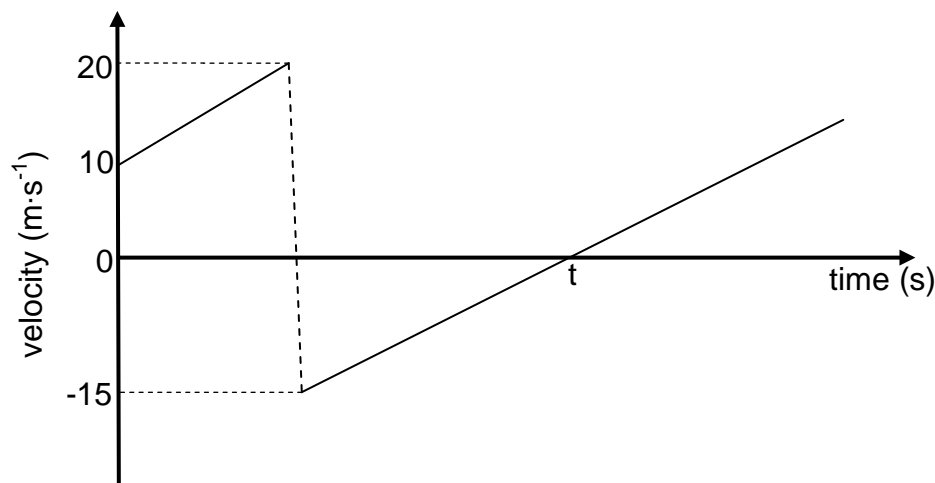

- 3.1 From the graph, write down the magnitude of the velocity at which the ball bounces off the floor. (1)
- 3.2 Is the collision of the ball with the floor ELASTIC or INELASTIC? Refer to the data on the graph to explain the answer. (3)
- 3.3 Calculate the:
 - 3.3.1 Height from which the ball is thrown (4)
 - 3.3.2 Magnitude of the impulse imparted by the floor on the ball (3)
 - 3.3.3 Magnitude of the displacement of the ball from the moment it is thrown until time t (4)

- 3.4 Sketch a position versus time graph for the motion of the ball from the moment it is thrown until it reaches its maximum height after the bounce. USE THE FLOOR AS THE ZERO POSITION.

Indicate the following on the graph:

- The height from which the ball is thrown
- Time t

(4)
[19]

QUESTION 4 (Start on a new page.)

A boy on ice skates is stationary on a frozen lake (no friction). He throws a package of mass 5 kg at $4 \text{ m}\cdot\text{s}^{-1}$ horizontally east as shown below. The mass of the boy is 60 kg.

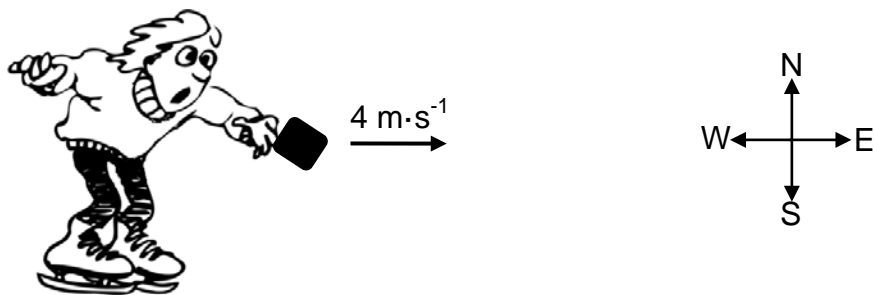

At the instant the package leaves the boy's hand, the boy starts moving.

- 4.1 In which direction does the boy move? Write down only EAST or WEST. (1)
- 4.2 Which ONE of Newton's laws of motion explains the direction in which the boy experiences a force when he throws the package? Name and state this law in words. (3)
- 4.3 Calculate the magnitude of the velocity of the boy immediately after the package leaves his hand. Ignore the effects of friction. (5)
- 4.4 How will the answer to QUESTION 4.3 be affected if:
(Write down INCREASES, DECREASES or REMAINS THE SAME.)
- 4.4.1 The boy throws the same package at a higher velocity in the same direction (1)
- 4.4.2 The boy throws a package of double the mass at the same velocity as in QUESTION 4.3. Explain the answer. (3)

[13]

QUESTION 5 (Start on a new page.)

A 5 kg rigid crate moves from rest down path **XYZ** as shown below (diagram not drawn to scale). Section **XY** of the path is frictionless. Assume that the crate moves in a straight line down the path.

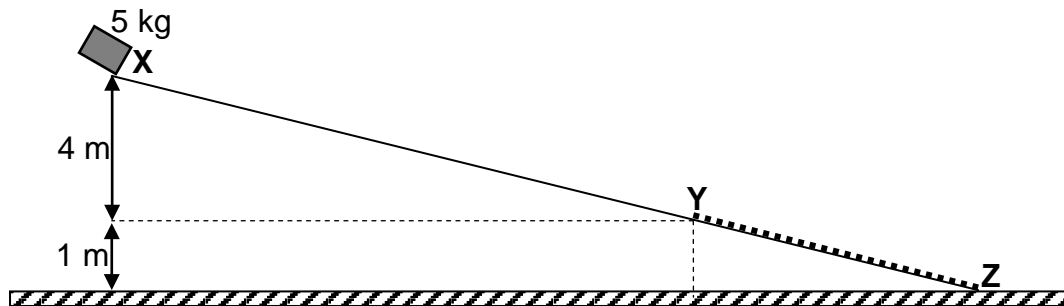

- 5.1 State, in words, the *principle of the conservation of mechanical energy*. (2)
- 5.2 Use the principle of the conservation of mechanical energy to calculate the speed of the crate when it reaches point **Y**. (4)

On reaching point **Y**, the crate continues to move down section **YZ** of the path. It experiences an average frictional force of 10 N and reaches point **Z** at a speed of $4 \text{ m}\cdot\text{s}^{-1}$.

- 5.3 APART FROM FRICTION, write down the names of TWO other forces that act on the crate while it moves down section **YZ**. (2)
- 5.4 In which direction does the net force act on the crate as it moves down section **YZ**? Write down only from '**Y to Z**' or from '**Z to Y**'. (1)
- 5.5 Use the WORK-ENERGY THEOREM to calculate the length of section **YZ**. (5)

Another crate of mass 10 kg now moves from point **X** down path **XYZ**.

- 5.6 How will the velocity of this 10 kg crate at point **Y** compare to that of the 5 kg crate at **Y**? Write down only GREATER THAN, SMALLER THAN or EQUAL TO. (1)
- [15]**

QUESTION 6 (Start on a new page.)

An ambulance approaches a stationary observer at a constant speed of $10,6 \text{ m}\cdot\text{s}^{-1}$, while its siren produces sound at a constant frequency of $954,3 \text{ Hz}$. The stationary observer measures the frequency of the sound as 985 Hz .

- 6.1 Name the medical instrument that makes use of the Doppler effect. (1)
- 6.2 Calculate the velocity of sound. (5)
- 6.3 How would the wavelength of the sound wave produced by the siren of the ambulance change if the frequency of the wave were higher than $954,3 \text{ Hz}$? Write down only INCREASES, DECREASES or STAYS THE SAME. (1)
- 6.4 Give a reason for the answer to QUESTION 6.3. (2)
- [9]**

QUESTION 7 (Start on a new page.)

Learners investigate how the broadness of the central bright band in a diffraction pattern changes as the wavelength of light changes. During the investigation, they perform two experiments. The slit width and the distance between the slit and the screen are kept constant.

In the first experiment, they pass light from a monochromatic source through a single slit and obtain pattern **P** on a screen. In the second experiment, they pass light from a different monochromatic source through the single slit and obtain pattern **Q** on the screen.

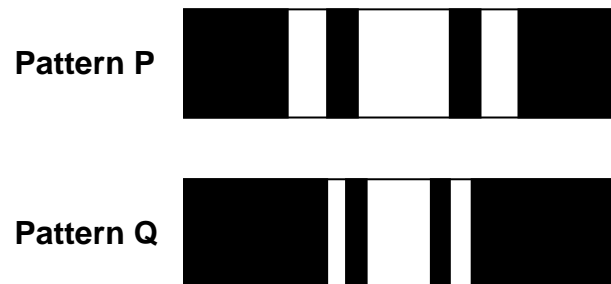

- 7.1 Define the term *diffraction*. (2)
- 7.2 Which ONE of the two patterns (**P** or **Q**) was obtained using the monochromatic light of a longer wavelength? (1)
- 7.3 For this investigation, write down the:
- 7.3.1 Dependent variable (1)
- 7.3.2 Investigative question (2)
- In ONE of their experiments, they use light of wavelength 410 nm and a slit width of 5×10^{-6} m.
- 7.4 Calculate the angle at which the SECOND MINIMUM will be observed on the screen. (5)
- 7.5 The single slit is now replaced with a double slit. Describe the pattern that will be observed on the screen. (2)

[13]

QUESTION 8 (Start on a new page.)

In the diagram below, point charge **A** has a charge of $+16 \mu\text{C}$. **X** is a point 12 cm from point charge **A**.

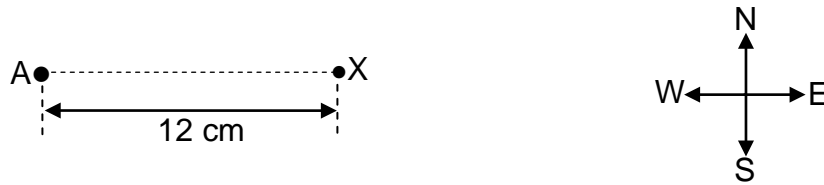

- 8.1 Draw the electric field pattern produced by point charge **A**. (2)
- 8.2 Is the electric field in QUESTION 8.1 UNIFORM or NON-UNIFORM? (1)
- 8.3 Calculate the magnitude and direction of the electric field at point **X** due to point charge **A**. (5)

Another point charge **B** is now placed at a distance of 35 cm from point charge **A** as shown below. The NET electric field at point **X** due to point charges **A** and **B** is $1 \times 10^7 \text{ N}\cdot\text{C}^{-1}$ west.

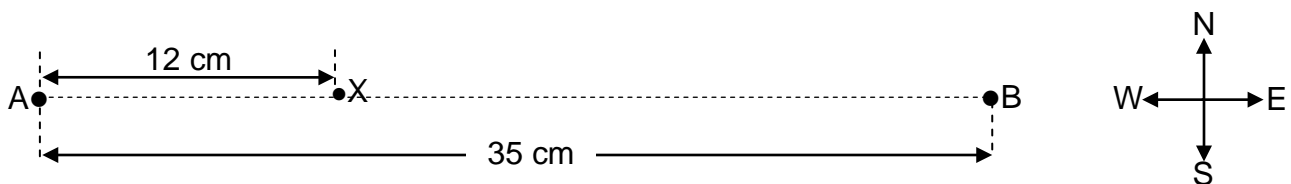

- 8.4 Is point charge **B** POSITIVE or NEGATIVE? (1)
- 8.5 Calculate the magnitude of point charge **B**. (5)
- [14]**

QUESTION 9 (Start on a new page.)

A learner wants to use a 12 V battery with an internal resistance of 1Ω to operate an electrical device. He uses the circuit below to obtain the desired potential difference for the device to function. The resistance of the device is 5Ω .

When switch **S** is **closed** as shown, the device functions at its maximum power of 5 W.

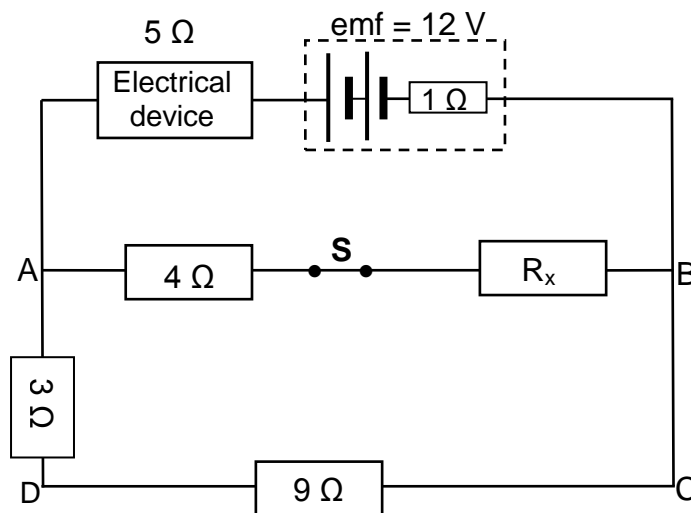

- 9.1 Explain, in words, the meaning of *an emf of 12 V*. (2)
- 9.2 Calculate the current that passes through the electrical device. (3)
- 9.3 Calculate the resistance of resistor R_x . (7)
- 9.4 Switch **S** is now **opened**. Will the device still function at maximum power? Write down YES or NO. Explain the answer without doing any calculations. (4)
- [16]**

QUESTION 10 (Start on a new page.)

The simplified sketch represents an AC generator. The main components are labelled **A**, **B**, **C** and **D**.

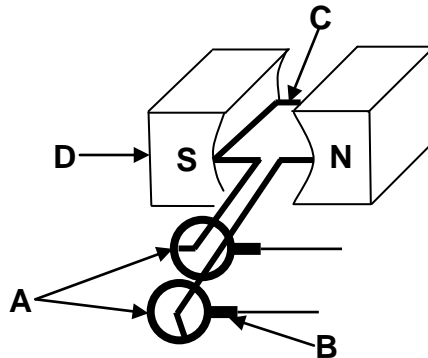

10.1 Write down the name of component:

10.1.1 **A** (1)

10.1.2 **B** (1)

10.2 Write down the function of component **B**. (1)

10.3 State the energy conversion which takes place in an AC generator. (1)

A similar coil is rotated in a magnetic field. The graph below shows how the alternating current produced by the AC generator varies with time.

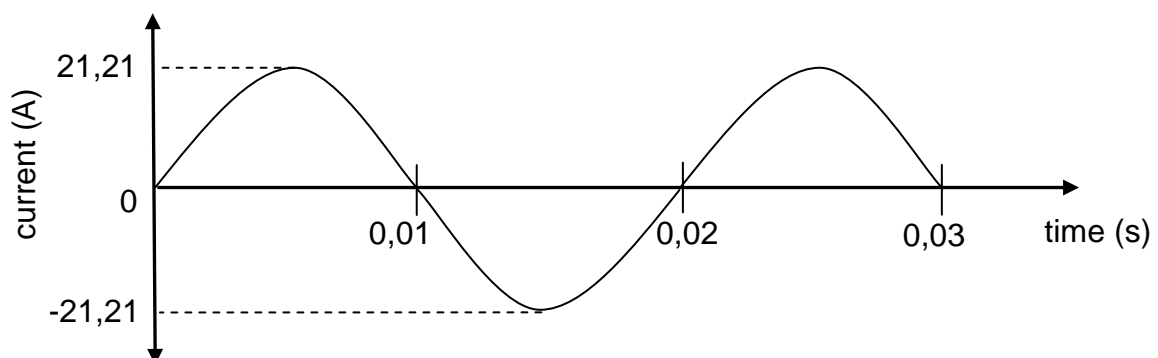

10.4 How many rotations are made by the coil in 0,03 seconds? (1)

10.5 Calculate the frequency of the alternating current. (3)

10.6 Will the plane of the coil be PERPENDICULAR TO or PARALLEL TO the magnetic field at $t = 0,015$ s? (1)

10.7 If the generator produces a maximum potential difference of 311 V, calculate its average power output. (5)

[14]

QUESTION 11 (Start on a new page.)

- 11.1 In the simplified diagram below, light is incident on the emitter of a photocell. The emitted photoelectrons move towards the collector and the ammeter registers a reading.

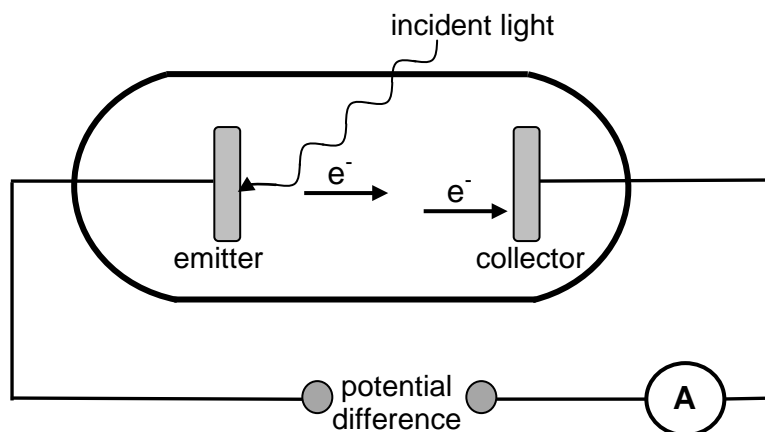

- 11.1.1 Name the phenomenon illustrated above. (1)
- 11.1.2 The work function of the metal used as emitter is $8,0 \times 10^{-19}$ J. The incident light has a wavelength of 200 nm.
Calculate the maximum speed at which an electron can be emitted. (5)
- 11.1.3 Incident light of a higher frequency is now used.
How will this change affect the maximum kinetic energy of the electron emitted in QUESTION 11.1.2? Write down only INCREASES, DECREASES or REMAINS THE SAME. (1)
- 11.1.4 The intensity of the incident light is now increased.
How will this change affect the speed of the electron calculated in QUESTION 11.1.2? Write down INCREASES, DECREASES or REMAINS THE SAME. Give a reason for the answer. (2)
- 11.2 A metal worker places two iron rods, **A** and **B**, in a furnace. After a while he observes that **A** glows deep red while **B** glows orange.
Which ONE of the rods (**A** or **B**) radiates more energy? Give a reason for the answer. (2)
- 11.3 Neon signs illuminate many buildings. What type of spectrum is produced by neon signs? (1)

[12]

TOTAL SECTION B: 125
GRAND TOTAL: 150

**DATA FOR PHYSICAL SCIENCES GRADE 12
PAPER 1 (PHYSICS)**

**GEGEWENS VIR FISIESTE WETENSAPPE GRAAD 12
VRAESTEL 1 (FISIKA)**

TABLE 1: PHYSICAL CONSTANTS/TABEL 1: FISIESTE KONSTANTES

NAME/NAAM	SYMBOL/SIMBOOL	VALUE/WAARDE
Acceleration due to gravity <i>Swaartekragversnelling</i>	g	9,8 m·s ⁻²
Speed of light in a vacuum <i>Spoed van lig in 'n vakuum</i>	c	3,0 x 10 ⁸ m·s ⁻¹
Planck's constant <i>Planck se konstante</i>	h	6,63 x 10 ⁻³⁴ J·s
Coulomb's constant <i>Coulomb se konstante</i>	k	9,0 x 10 ⁹ N·m ² ·C ⁻²
Charge on electron <i>Lading op elektron</i>	e	-1,6 x 10 ⁻¹⁹ C
Electron mass <i>Elektronmassa</i>	m _e	9,11 x 10 ⁻³¹ kg
Permittivity of free space <i>Permittiwiteit van vry ruimte</i>	ε ₀	8,85 x 10 ⁻¹² F·m ⁻¹

TABLE 2: FORMULAE/TABEL 2: FORMULES**MOTION/BEWEGING**

$v_f = v_i + a \Delta t$	$\Delta x = v_i \Delta t + \frac{1}{2} a \Delta t^2$ or/of $\Delta y = v_i \Delta t + \frac{1}{2} a \Delta t^2$
$v_f^2 = v_i^2 + 2a\Delta x$ or/of $v_f^2 = v_i^2 + 2a\Delta y$	$\Delta x = \left(\frac{v_i + v_f}{2} \right) \Delta t$ or/of $\Delta y = \left(\frac{v_i + v_f}{2} \right) \Delta t$

FORCE/KRAG

$F_{\text{net}} = ma$	$p = mv$
$F_{\text{net}} \Delta t = \Delta p$ $\Delta p = mv_f - mv_i$	$w = mg$

WORK, ENERGY AND POWER/ARBEID, ENERGIE EN DRYWING

$W = F \Delta x \cos \theta$	$U = mgh$ or/of $E_p = mgh$
$K = \frac{1}{2} mv^2$ or/of $E_k = \frac{1}{2} mv^2$	$W_{\text{net}} = \Delta K$ or/of $W_{\text{net}} = \Delta E_k$ $\Delta K = K_f - K_i$ or/of $\Delta E_k = E_{kf} - E_{ki}$
$P = \frac{W}{\Delta t}$	$P = Fv$

WAVES, SOUND AND LIGHT/GOLWE, KLANK EN LIG

$v = f \lambda$	$T = \frac{1}{f}$
$f_L = \frac{v \pm v_L}{v \pm v_s} f_s$ or/of $f_L = \frac{v \pm v_L}{v \pm v_b} f_b$	$E = hf$ $E = h \frac{c}{\lambda}$
$\sin \theta = \frac{m\lambda}{a}$	$E = W_0 + E_k$ where/waar $E = hf$ and/en $W_0 = hf_0$ and/en $E_k = \frac{1}{2} mv^2$

ELECTROSTATICS/ELEKTROSTATIKA

$F = \frac{kQ_1Q_2}{r^2}$	$E = \frac{kQ}{r^2}$
$E = \frac{V}{d}$	$E = \frac{F}{q}$
$U = \frac{kQ_1Q_2}{r}$	$V = \frac{W}{q}$
$C = \frac{Q}{V}$	$C = \frac{\epsilon_0 A}{d}$

ELECTRIC CIRCUITS/ELEKTRIESE STROOMBANE

$R = \frac{V}{I}$	emf (ϵ) = $I(R + r)$ emk (ϵ) = $I(R + r)$
$R_s = R_1 + R_2 + \dots$ $\frac{1}{R_p} = \frac{1}{R_1} + \frac{1}{R_2} + \dots$	$q = I \Delta t$
$W = Vq$ $W = VI \Delta t$ $W = I^2 R \Delta t$ $W = \frac{V^2 \Delta t}{R}$	$P = \frac{W}{\Delta t}$ $P = VI$ $P = I^2 R$ $P = \frac{V^2}{R}$

ALTERNATING CURRENT/WISSELSTROOM

$I_{\text{rms}} = \frac{I_{\text{max}}}{\sqrt{2}}$ / $I_{\text{wgk}} = \frac{I_{\text{maks}}}{\sqrt{2}}$	$P_{\text{average}} = V_{\text{rms}} I_{\text{rms}}$ / $P_{\text{gemiddeld}} = V_{\text{wgk}} I_{\text{wgk}}$
$V_{\text{rms}} = \frac{V_{\text{max}}}{\sqrt{2}}$ / $V_{\text{wgk}} = \frac{V_{\text{maks}}}{\sqrt{2}}$	$P_{\text{average}} = I_{\text{rms}}^2 R$ / $P_{\text{gemiddeld}} = I_{\text{wgk}}^2 R$
	$P_{\text{average}} = \frac{V_{\text{rms}}^2}{R}$ / $P_{\text{gemiddeld}} = \frac{V_{\text{wgk}}^2}{R}$