



basic education

Department:
Basic Education
REPUBLIC OF SOUTH AFRICA

NATIONAL SENIOR CERTIFICATE

GRADE 12

PHYSICAL SCIENCES: CHEMISTRY (P2)

FEBRUARY/MARCH 2014

MARKS: 150

TIME: 3 hours

This question paper consists of 13 pages and 4 data sheets.

INSTRUCTIONS AND INFORMATION

1. Write your centre number and examination number in the appropriate spaces on the ANSWER BOOK.
2. Answer ALL the questions in the ANSWER BOOK.
3. This question paper consists of TWO sections:

SECTION A (25)
SECTION B (125)
4. You may use a non-programmable calculator.
5. You may use appropriate mathematical instruments.
6. Number the answers correctly according to the numbering system used in this question paper.
7. Data sheets and a periodic table are attached for your use.
8. Give brief motivations, discussions, et cetera where required.
9. Round off your final numerical answers to a minimum of TWO decimal places.

SECTION A**QUESTION 1: ONE-WORD ITEMS**

Give ONE word/term for each of the following descriptions. Write only the word/term next to the question number (1.1–1.5) in the ANSWER BOOK.

- 1.1 The general name given to compounds formed when one or more hydrogen atoms in alkanes are replaced with halogens (1)
- 1.2 The homologous series of compounds with the general formula C_nH_{2n-2} (1)
- 1.3 The minimum energy needed for a reaction to occur (1)
- 1.4 The coating of one metal with another by the process of electrolysis (1)
- 1.5 The name of the industrial process used in the preparation of nitric acid (1)
- [5]**

QUESTION 2: MULTIPLE-CHOICE QUESTIONS

Four options are given as possible answers to the following questions. Each question has only ONE correct answer. Write only the letter (A–D) next to the question number (2.1–2.10) in the ANSWER BOOK.

- 2.1 Which ONE of the following compounds is a ketone?
- A $CH_3COCH_2CH_3$
- B $CH_3COOCH_2CH_3$
- C $CH_3CH_2CH_2CHO$
- D $CH_3CH(OH)CH_2CH_3$ (2)
- 2.2 Which ONE of the following compounds is SATURATED?
- A $CH_3CH(CH_3)CH_3$
- B $CH_3CH_2CHCH_2$
- C $CH_3CHCHCH_3$
- D $CH_3C(CH_3)_2CHCH_2$ (2)
- 2.3 A scientist investigates a factor which influences the boiling points of alkanes. He determines the boiling points of the first six straight chain alkanes. Which ONE of the following is the independent variable in this investigation?
- A Boiling point
- B Functional group
- C Branching
- D Chain length (2)

- 2.4 The temperature of a substance is a measure of the ... of the particles.
- A average potential energy
- B average kinetic energy
- C total kinetic energy
- D total potential energy (2)
- 2.5 The graph below shows a change made to a chemical equilibrium in a closed container at time t_1 . The equation for the reaction is:

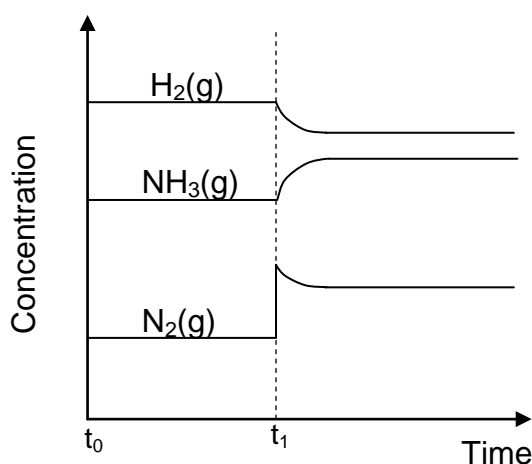
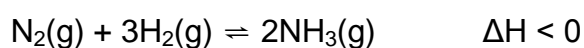

Which ONE of the following is the change made at time t_1 ?

- A Addition of a catalyst
- B Increase in temperature
- C Increase in the concentration of $\text{N}_2(\text{g})$
- D Increase in pressure by decreasing the volume (2)
- 2.6 In a chemical reaction, the difference between the potential energy of the products and the potential energy of the reactants is equal to the ...
- A enthalpy of the reaction.
- B rate of the reaction.
- C enthalpy change of the reaction.
- D total potential energy of the particles. (2)

2.7 Consider the galvanic cell represented below.



Which ONE of the following half-reactions takes place at the cathode?

- A $\text{H}_2(\text{g}) \rightarrow 2\text{H}^{+}(\text{aq}) + 2\text{e}^{-}$
- B $\text{Mg}^{2+}(\text{aq}) + 2\text{e}^{-} \rightarrow \text{Mg(s)}$
- C $\text{Mg(s)} \rightarrow \text{Mg}^{2+}(\text{aq}) + 2\text{e}^{-}$
- D $2\text{H}^{+}(\text{aq}) + 2\text{e}^{-} \rightarrow \text{H}_2(\text{g})$ (2)

2.8 Consider an electrochemical cell based on the following reaction:

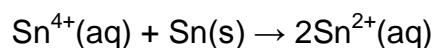

Which ONE of the following statements regarding this cell is CORRECT?

- A Sn is the anode of the cell.
- B Sn is the cathode of the cell.
- C $\text{Sn}^{4+}(\text{aq})$ is the reducing agent.
- D Sn is the oxidising agent. (2)

2.9 Which ONE of the following statements regarding an electrolytic cell is CORRECT?

- A An electric current causes a chemical change to occur.
- B Reduction occurs at the anode.
- C A spontaneous chemical reaction produces an electric current.
- D Electrons flow to the electrode where oxidation occurs. (2)

2.10 Which ONE of the following is formed at the cathode in a membrane cell?

- A Chlorine
 - B Hydrogen
 - C Sodium chloride
 - D Oxygen (2)
- [20]

TOTAL SECTION A: 25

SECTION B**INSTRUCTIONS**

1. Start EACH question on a NEW page.
2. Leave ONE line between two subquestions, for example between QUESTION 3.1 and QUESTION 3.2.
3. Show the formulae and substitutions in ALL calculations.
4. Round off your final numerical answers to a minimum of TWO decimal places.

QUESTION 3 (Start on a new page.)

The letters **A** to **F** in the table below represent six organic compounds.

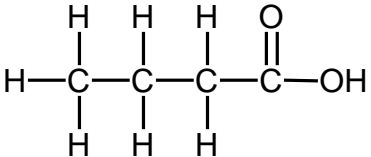
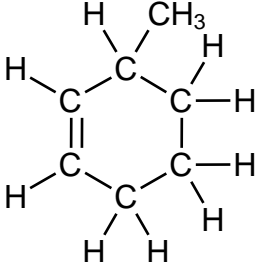
A		B	butan-2-ol
C		D	pentanal
E	C_2H_5OH	F	methyl propanoate

- 3.1 Write down the letter that represents a compound that:
- 3.1.1 Is unsaturated (1)
 - 3.1.2 Is a structural isomer of compound **A** (1)
 - 3.1.3 Is an aldehyde (1)
 - 3.1.4 Belongs to the same homologous series as compound **B** (1)
- 3.2 Write down the:
- 3.2.1 IUPAC name of compound **C** (2)
 - 3.2.2 Structural formula of compound **B** (2)
 - 3.2.3 Name of the homologous series to which compound **F** belongs (1)

- 3.3 Compound **A** reacts with compound **E** in an acid catalysed condensation reaction.

Write down the:

- 3.3.1 General name given to this reaction (1)
- 3.3.2 Structural formula of the organic product formed (2)
- 3.3.3 IUPAC name of compound **A** (1)
- [13]**

QUESTION 4 (Start on a new page.)

Petrol is a mixture of hydrocarbons, many of which have the molecular formula C_8H_{18} .

- 4.1 Write down the name of the homologous series to which hydrocarbons with this molecular formula belong. (1)

The structures of two compounds with molecular formula C_8H_{18} are given below.

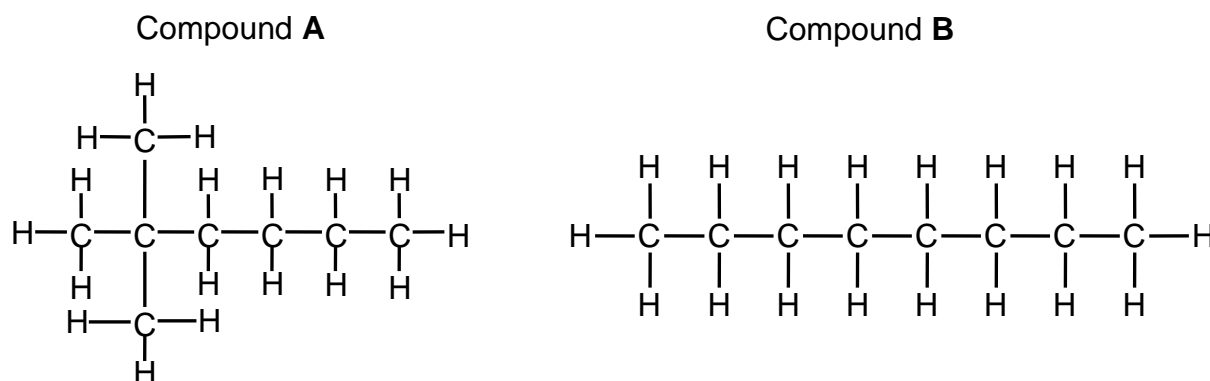

- 4.2 Why are compounds **A** and **B** *structural isomers*? (2)
- 4.3 Which ONE of the above compounds (**A** or **B**) has a higher boiling point? Refer to MOLECULAR STRUCTURE, INTERMOLECULAR FORCES and the ENERGY NEEDED to explain the answer. (4)
- 4.4 Compounds **A** and **B** can be used to prepare smaller hydrocarbons at high temperatures in the presence of a catalyst. One such reaction is represented by the incomplete equation below.

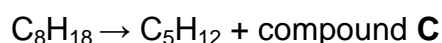

Write down the:

- 4.4.1 Name of the reaction represented above (1)
- 4.4.2 Structural formula of compound **C** (2)
- 4.4.3 Balanced equation, using molecular formulae, for the complete combustion of C_5H_{12} (3)
- [13]**

QUESTION 5 (Start on a new page.)

The flow diagram below shows the steps that a learner follows to convert but-1-ene to but-2-ene.

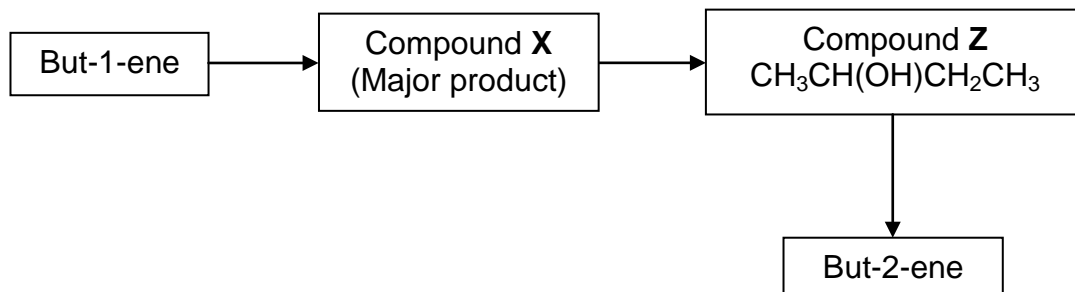

- 5.1 Write down the structural formula of the functional group of but-1-ene. (1)
- 5.2 Compound **X** is formed when but-1-ene reacts with HCl(g) .
- 5.2.1 Name the type of reaction that takes place. (1)
- 5.2.2 Write down the structural formula of compound **X**. (2)
- 5.3 Compound **X** is converted to alcohol **Z**.
- 5.3.1 Name the type of reaction that takes place. (1)
- 5.3.2 Write down the NAME or FORMULA of another reactant needed for this reaction. (1)
- 5.4 Compound **Z** is converted to but-2-ene in the presence of concentrated sulphuric acid.
- 5.4.1 Is compound **Z** a PRIMARY, SECONDARY or TERTIARY alcohol? (1)
- 5.4.2 Name the type of reaction that takes place. (1)
- 5.4.3 What is the role of sulphuric acid in this reaction? (1)
- 5.5 Another learner discovers that but-2-ene can be prepared using the following incomplete reaction below.

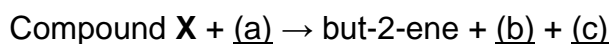

Write down the:

- 5.5.1 Type of reaction that takes place (1)
- 5.5.2 Conditions needed for this reaction to take place (2)
- 5.5.3 FORMULAE of the reactant and products represented by each of the letters (a), (b) and (c) respectively (3)

[15]

QUESTION 6 (Start on a new page.)

The graph below shows the decomposition of gas **P** according to the following equation:

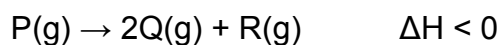

Graph of concentration of P versus time

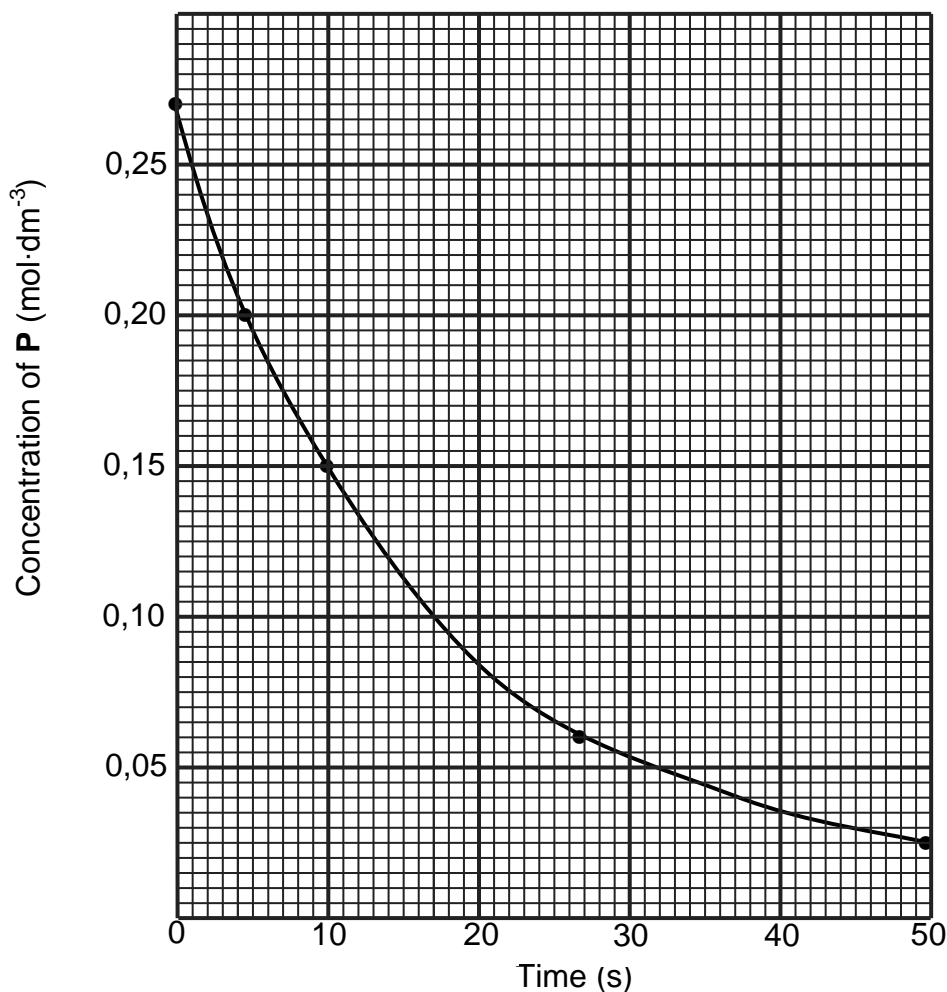

- 6.1 Define the term *rate of reaction* in words by referring to the graph. (2)
- 6.2 At which time, 10 s or 30 s, does the decomposition take place at a higher rate? Refer to the graph to give a reason for the answer. (2)
- 6.3 Write down the initial concentration of **P(g)**. (1)
- 6.4 The decomposition is carried out in a 2 dm³ container.
Calculate the average rate (in mol·s⁻¹) at which **P(g)** is decomposed in the first 10 s. (6)

6.5 Draw a potential energy diagram for the reaction. Clearly indicate the following on the diagram:

- Positions of the reactants and products
 - Activation energy (E_a) for the forward reaction
- (3)

6.6 An increase in temperature will increase the rate of decomposition of P(g).

Explain this statement in terms of the collision theory.

(2)
[16]

QUESTION 7 (Start on a new page.)

The reaction of methane gas (CH_4) with steam (H_2O) produces hydrogen gas. The equation for the reaction is shown below.

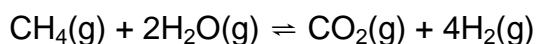

7.1 Briefly explain why the CO_2 gas may be harmful to the environment. (2)

Initially, 1 mol of methane and 2 mol of steam are sealed in a $5,0 \text{ dm}^3$ container. When equilibrium is established at temperature T_1 , the mixture contains 0,3 mol of $\text{CO}_2(\text{g})$.

7.2 Define the term *chemical equilibrium*. (2)

7.3 Calculate the equilibrium constant (K_C) at T_1 . (7)

7.4 A new equilibrium is now established at a higher temperature T_2 . The value of the equilibrium constant (K_C) at this new temperature is 0,01.

Is this reaction exothermic or endothermic? Use Le Chatelier's principle and the value of K_C at T_1 and T_2 to explain the answer.

(4)
[15]

QUESTION 8 (Start on a new page.)

The diagram below represents a galvanic cell operating under standard conditions.

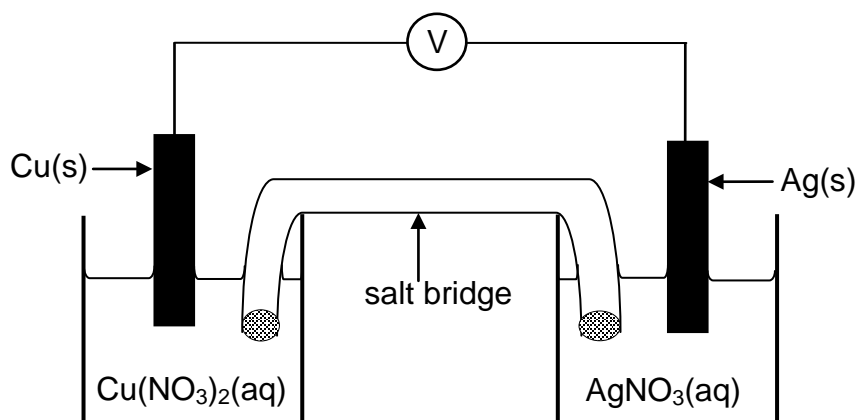

- 8.1 Write down:
- 8.1.1 The energy conversion which takes place in this cell (1)
- 8.1.2 A balanced equation for the overall cell reaction (3)
- 8.1.3 The cell notation for this cell (3)
- 8.2 Calculate the initial emf of this cell. (4)
- 8.3 In which direction will electrons flow? Write down only 'from Ag to Cu' or 'from Cu to Ag'. (1)
- 8.4 The cell is allowed to discharge for a period of time during which the mass of the copper electrode changes by 3,2 g.
- Calculate the expected mass change of the silver electrode. (Assume that the change in mass is only a result of the oxidation-reduction reaction occurring as the cell discharges.) (4)
- 8.5 The silver half-cell is now replaced with the standard hydrogen half-cell.
- 8.5.1 Is the copper electrode the POSITIVE or the NEGATIVE electrode? Refer to the relative strength of reducing agents to explain the answer. (4)
- 8.5.2 Write down the emf of this cell. (1)
- [21]**

QUESTION 9 (Start on a new page.)

The diagram below represents the apparatus used in the electrolysis of a concentrated CuCl_2 solution. **A** and **B** are two carbon electrodes connected to a power supply.

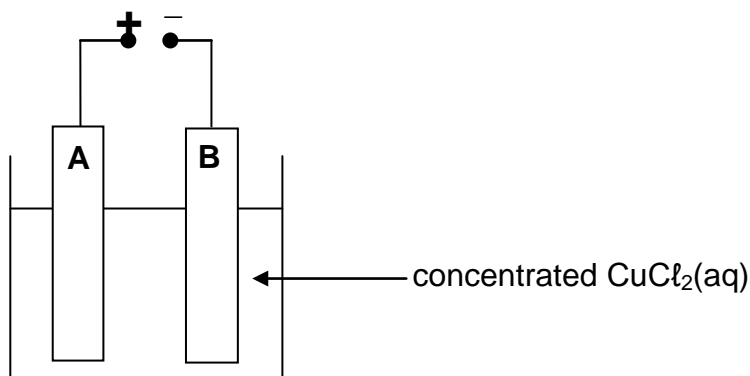

- 9.1 Which electrode (**A** or **B**) is the anode? (1)
- 9.2 Is the electrolytic process endothermic or exothermic? (1)
- 9.3 Write down THREE observations that can be made during this process. (3)
- 9.4 Write down the overall cell reaction. (3)
- 9.5 Give ONE reason why the salt needs to be in solution in this process. (1)
- [9]**

QUESTION 10 (Start on a new page.)

A hydrogen-oxygen fuel cell consists of an electrolytic solution such as potassium hydroxide and two inert electrodes. Hydrogen and oxygen are bubbled into the cell and the following half-reactions occur:

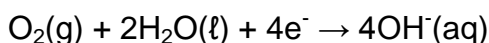
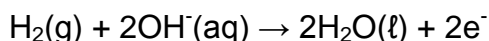

- 10.1 Write down the overall cell reaction for this cell. (3)
- 10.2 Give a reason why this cell is regarded as environmentally friendly. (1)
- 10.3 Calculate the initial emf of this cell. (4)
- 10.4 Calculate the energy stored in the cell if it has a capacity of 1 A·h. (5)
- [13]**

QUESTION 11 (Start on a new page.)

Sulphuric acid is produced by the contact process and is used in the production of fertilisers such as ammonium sulphate.

11.1 In one of the steps in this process, sulphur trioxide is dissolved in sulphuric acid rather than in water to produce oleum.

11.1.1 Write down a balanced equation showing how oleum is produced. (3)

11.1.2 Give a reason why sulphur trioxide is not dissolved in water to produce sulphuric acid. (1)

11.2 A farmer wants to use a fertiliser which promotes root growth in his vegetable garden. He must choose between ammonium sulphate, ammonium nitrate and ammonium phosphate.

The percentage of the elements in each of the fertilisers is given in the table below.

ELEMENT	AMMONIUM SULPHATE	AMMONIUM NITRATE	AMMONIUM PHOSPHATE
Nitrogen	21,21	35	28,19
Sulphur	24,24	0	0
Phosphorous	0	0	20,8

11.2.1 Which ONE of the above fertilisers will be the best choice? Refer to the data in the table to give a reason for the answer. (2)

11.2.2 Write down TWO negative impacts of the overuse of fertiliser on the environment. (4)
[10]

TOTAL SECTION B: 125
GRAND TOTAL: 150

**DATA FOR PHYSICAL SCIENCES GRADE 12
PAPER 2 (CHEMISTRY)**

**GEGEWENS VIR FISIESTE WETENSAPPE GRAAD 12
VRAESTEL 2 (CHEMIE)**

TABLE 1: PHYSICAL CONSTANTS/TABEL 1: FISIESTE KONSTANTES

NAME/NAAM	SYMBOL/SIMBOOL	VALUE/WAARDE
Standard pressure <i>Standaarddruk</i>	p^θ	$1,013 \times 10^5 \text{ Pa}$
Molar gas volume at STP <i>Molêre gasvolume by STD</i>	V_m	$22,4 \text{ dm}^3 \cdot \text{mol}^{-1}$
Standard temperature <i>Standaardtemperatuur</i>	T^θ	273 K
Charge on electron <i>Lading op elektron</i>	e	$-1,6 \times 10^{-19} \text{ C}$

TABLE 2: FORMULAE/TABEL 2: FORMULES

$n = \frac{m}{M}$	$c = \frac{n}{V}$ or/of $c = \frac{m}{MV}$
$q = I \Delta t$ $W = Vq$	$E_{\text{cell}}^\theta = E_{\text{cathode}}^\theta - E_{\text{anode}}^\theta / E_{\text{sel}}^\theta = E_{\text{katode}}^\theta - E_{\text{anode}}^\theta$ or/of $E_{\text{cell}}^\theta = E_{\text{reduction}}^\theta - E_{\text{oxidation}}^\theta / E_{\text{sel}}^\theta = E_{\text{reduksie}}^\theta - E_{\text{oksidasie}}^\theta$ or/of $E_{\text{cell}}^\theta = E_{\text{oxidising agent}}^\theta - E_{\text{reducing agent}}^\theta / E_{\text{sel}}^\theta = E_{\text{oksideermiddel}}^\theta - E_{\text{reduseermiddel}}^\theta$

TABLE 4A: STANDARD REDUCTION POTENTIALS
TABEL 4A: STANDAARD-REDUKSIEPOTENSIALE

Half-reactions/ <i>Halfreaksies</i>	E^{\ominus} (V)
$F_2(g) + 2e^- \rightleftharpoons 2F^-$	+ 2,87
$Co^{3+} + e^- \rightleftharpoons Co^{2+}$	+ 1,81
$H_2O_2 + 2H^+ + 2e^- \rightleftharpoons 2H_2O$	+1,77
$MnO_4^- + 8H^+ + 5e^- \rightleftharpoons Mn^{2+} + 4H_2O$	+ 1,51
$Cl_2(g) + 2e^- \rightleftharpoons 2Cl^-$	+ 1,36
$Cr_2O_7^{2-} + 14H^+ + 6e^- \rightleftharpoons 2Cr^{3+} + 7H_2O$	+ 1,33
$O_2(g) + 4H^+ + 4e^- \rightleftharpoons 2H_2O$	+ 1,23
$MnO_2 + 4H^+ + 2e^- \rightleftharpoons Mn^{2+} + 2H_2O$	+ 1,23
$Pt^{2+} + 2e^- \rightleftharpoons Pt$	+ 1,20
$Br_2(l) + 2e^- \rightleftharpoons 2Br^-$	+ 1,07
$NO_3^- + 4H^+ + 3e^- \rightleftharpoons NO(g) + 2H_2O$	+ 0,96
$Hg^{2+} + 2e^- \rightleftharpoons Hg(l)$	+ 0,85
$Ag^+ + e^- \rightleftharpoons Ag$	+ 0,80
$NO_3^- + 2H^+ + e^- \rightleftharpoons NO_2(g) + H_2O$	+ 0,80
$Fe^{3+} + e^- \rightleftharpoons Fe^{2+}$	+ 0,77
$O_2(g) + 2H^+ + 2e^- \rightleftharpoons H_2O_2$	+ 0,68
$I_2 + 2e^- \rightleftharpoons 2I^-$	+ 0,54
$Cu^+ + e^- \rightleftharpoons Cu$	+ 0,52
$SO_2 + 4H^+ + 4e^- \rightleftharpoons S + 2H_2O$	+ 0,45
$2H_2O + O_2 + 4e^- \rightleftharpoons 4OH^-$	+ 0,40
$Cu^{2+} + 2e^- \rightleftharpoons Cu$	+ 0,34
$SO_4^{2-} + 4H^+ + 2e^- \rightleftharpoons SO_2(g) + 2H_2O$	+ 0,17
$Cu^{2+} + e^- \rightleftharpoons Cu^+$	+ 0,16
$Sn^{4+} + 2e^- \rightleftharpoons Sn^{2+}$	+ 0,15
$S + 2H^+ + 2e^- \rightleftharpoons H_2S(g)$	+ 0,14
$2H^+ + 2e^- \rightleftharpoons H_2(g)$	0,00
$Fe^{3+} + 3e^- \rightleftharpoons Fe$	- 0,06
$Pb^{2+} + 2e^- \rightleftharpoons Pb$	- 0,13
$Sn^{2+} + 2e^- \rightleftharpoons Sn$	- 0,14
$Ni^{2+} + 2e^- \rightleftharpoons Ni$	- 0,27
$Co^{2+} + 2e^- \rightleftharpoons Co$	- 0,28
$Cd^{2+} + 2e^- \rightleftharpoons Cd$	- 0,40
$Cr^{3+} + e^- \rightleftharpoons Cr^{2+}$	- 0,41
$Fe^{2+} + 2e^- \rightleftharpoons Fe$	- 0,44
$Cr^{3+} + 3e^- \rightleftharpoons Cr$	- 0,74
$Zn^{2+} + 2e^- \rightleftharpoons Zn$	- 0,76
$2H_2O + 2e^- \rightleftharpoons H_2(g) + 2OH^-$	- 0,83
$Cr^{2+} + 2e^- \rightleftharpoons Cr$	- 0,91
$Mn^{2+} + 2e^- \rightleftharpoons Mn$	- 1,18
$Al^{3+} + 3e^- \rightleftharpoons Al$	- 1,66
$Mg^{2+} + 2e^- \rightleftharpoons Mg$	- 2,36
$Na^+ + e^- \rightleftharpoons Na$	- 2,71
$Ca^{2+} + 2e^- \rightleftharpoons Ca$	- 2,87
$Sr^{2+} + 2e^- \rightleftharpoons Sr$	- 2,89
$Ba^{2+} + 2e^- \rightleftharpoons Ba$	- 2,90
$Cs^+ + e^- \rightleftharpoons Cs$	- 2,92
$K^+ + e^- \rightleftharpoons K$	- 2,93
$Li^+ + e^- \rightleftharpoons Li$	- 3,05

Increasing oxidising ability/*Toenemende oksiderende vermoë*

Increasing reducing ability/*Toenemende reduserende vermoë*

TABLE 4B: STANDARD REDUCTION POTENTIALS
TABEL 4B: STANDAARD-REDUKSIEPOTENSIALE

Half-reactions/ <i>Halfreaksies</i>	E^{\ominus} (V)
$\text{Li}^+ + e^- \rightleftharpoons \text{Li}$	-3,05
$\text{K}^+ + e^- \rightleftharpoons \text{K}$	-2,93
$\text{Cs}^+ + e^- \rightleftharpoons \text{Cs}$	-2,92
$\text{Ba}^{2+} + 2e^- \rightleftharpoons \text{Ba}$	-2,90
$\text{Sr}^{2+} + 2e^- \rightleftharpoons \text{Sr}$	-2,89
$\text{Ca}^{2+} + 2e^- \rightleftharpoons \text{Ca}$	-2,87
$\text{Na}^+ + e^- \rightleftharpoons \text{Na}$	-2,71
$\text{Mg}^{2+} + 2e^- \rightleftharpoons \text{Mg}$	-2,36
$\text{Al}^{3+} + 3e^- \rightleftharpoons \text{Al}$	-1,66
$\text{Mn}^{2+} + 2e^- \rightleftharpoons \text{Mn}$	-1,18
$\text{Cr}^{2+} + 2e^- \rightleftharpoons \text{Cr}$	-0,91
$2\text{H}_2\text{O} + 2e^- \rightleftharpoons \text{H}_2(\text{g}) + 2\text{OH}^-$	-0,83
$\text{Zn}^{2+} + 2e^- \rightleftharpoons \text{Zn}$	-0,76
$\text{Cr}^{3+} + 3e^- \rightleftharpoons \text{Cr}$	-0,74
$\text{Fe}^{2+} + 2e^- \rightleftharpoons \text{Fe}$	-0,44
$\text{Cr}^{3+} + e^- \rightleftharpoons \text{Cr}^{2+}$	-0,41
$\text{Cd}^{2+} + 2e^- \rightleftharpoons \text{Cd}$	-0,40
$\text{Co}^{2+} + 2e^- \rightleftharpoons \text{Co}$	-0,28
$\text{Ni}^{2+} + 2e^- \rightleftharpoons \text{Ni}$	-0,27
$\text{Sn}^{2+} + 2e^- \rightleftharpoons \text{Sn}$	-0,14
$\text{Pb}^{2+} + 2e^- \rightleftharpoons \text{Pb}$	-0,13
$\text{Fe}^{3+} + 3e^- \rightleftharpoons \text{Fe}$	-0,06
$2\text{H}^+ + 2e^- \rightleftharpoons \text{H}_2(\text{g})$	0,00
$\text{S} + 2\text{H}^+ + 2e^- \rightleftharpoons \text{H}_2\text{S}(\text{g})$	+0,14
$\text{Sn}^{4+} + 2e^- \rightleftharpoons \text{Sn}^{2+}$	+0,15
$\text{Cu}^{2+} + e^- \rightleftharpoons \text{Cu}^+$	+0,16
$\text{SO}_4^{2-} + 4\text{H}^+ + 2e^- \rightleftharpoons \text{SO}_2(\text{g}) + 2\text{H}_2\text{O}$	+0,17
$\text{Cu}^{2+} + 2e^- \rightleftharpoons \text{Cu}$	+0,34
$2\text{H}_2\text{O} + \text{O}_2 + 4e^- \rightleftharpoons 4\text{OH}^-$	+0,40
$\text{SO}_2 + 4\text{H}^+ + 4e^- \rightleftharpoons \text{S} + 2\text{H}_2\text{O}$	+0,45
$\text{Cu}^+ + e^- \rightleftharpoons \text{Cu}$	+0,52
$\text{I}_2 + 2e^- \rightleftharpoons 2\text{I}^-$	+0,54
$\text{O}_2(\text{g}) + 2\text{H}^+ + 2e^- \rightleftharpoons \text{H}_2\text{O}_2$	+0,68
$\text{Fe}^{3+} + e^- \rightleftharpoons \text{Fe}^{2+}$	+0,77
$\text{NO}_3^- + 2\text{H}^+ + e^- \rightleftharpoons \text{NO}_2(\text{g}) + \text{H}_2\text{O}$	+0,80
$\text{Ag}^+ + e^- \rightleftharpoons \text{Ag}$	+0,80
$\text{Hg}^{2+} + 2e^- \rightleftharpoons \text{Hg}(\ell)$	+0,85
$\text{NO}_3^- + 4\text{H}^+ + 3e^- \rightleftharpoons \text{NO}(\text{g}) + 2\text{H}_2\text{O}$	+0,96
$\text{Br}_2(\ell) + 2e^- \rightleftharpoons 2\text{Br}^-$	+1,07
$\text{Pt}^{2+} + 2e^- \rightleftharpoons \text{Pt}$	+1,20
$\text{MnO}_2 + 4\text{H}^+ + 2e^- \rightleftharpoons \text{Mn}^{2+} + 2\text{H}_2\text{O}$	+1,23
$\text{O}_2(\text{g}) + 4\text{H}^+ + 4e^- \rightleftharpoons 2\text{H}_2\text{O}$	+1,23
$\text{Cr}_2\text{O}_7^{2-} + 14\text{H}^+ + 6e^- \rightleftharpoons 2\text{Cr}^{3+} + 7\text{H}_2\text{O}$	+1,33
$\text{Cl}_2(\text{g}) + 2e^- \rightleftharpoons 2\text{Cl}^-$	+1,36
$\text{MnO}_4^- + 8\text{H}^+ + 5e^- \rightleftharpoons \text{Mn}^{2+} + 4\text{H}_2\text{O}$	+1,51
$\text{H}_2\text{O}_2 + 2\text{H}^+ + 2e^- \rightleftharpoons 2\text{H}_2\text{O}$	+1,77
$\text{Co}^{3+} + e^- \rightleftharpoons \text{Co}^{2+}$	+1,81
$\text{F}_2(\text{g}) + 2e^- \rightleftharpoons 2\text{F}^-$	+2,87

Increasing oxidising ability/*Toenemende oksiderende vermoë*

Increasing reducing ability/*Toenemende reduserende vermoë*