



basic education

Department:
Basic Education
REPUBLIC OF SOUTH AFRICA

NATIONAL SENIOR CERTIFICATE

GRADE 12

PHYSICAL SCIENCES: CHEMISTRY (P2)

FEBRUARY/MARCH 2013

MARKS: 150

TIME: 3 hours

This question paper consists of 15 pages and 4 data sheets.

INSTRUCTIONS AND INFORMATION

1. Write your centre number and examination number in the appropriate spaces on the ANSWER BOOK.
2. Answer ALL the questions in the ANSWER BOOK.
3. This question paper consists of TWO sections:

SECTION A (25)
SECTION B (125)
4. You may use a non-programmable calculator.
5. You may use appropriate mathematical instruments.
6. Number the answers correctly according to the numbering system used in this question paper.
7. Data sheets and a periodic table are attached for your use.
8. Give brief motivations, discussions, et cetera where required.
9. Round off your final numerical answers to a minimum of TWO decimal places.

SECTION A**QUESTION 1: ONE-WORD ITEMS**

Give ONE word/term for each of the following descriptions. Write only the word/term next to the question number (1.1–1.5) in the ANSWER BOOK.

- 1.1 The homologous series to which compounds with the functional group –OH belong (1)
- 1.2 The process in which large alkane molecules are broken up into smaller alkanes and alkenes (1)
- 1.3 The amount of products formed or reactants used per unit time in a chemical reaction (1)
- 1.4 The process in which electricity is used to decompose a chemical substance (1)
- 1.5 The name of the industrial process used in the production of ammonia (1)
- [5]**

QUESTION 2: MULTIPLE-CHOICE QUESTIONS

Four options are provided as possible answers to the following questions. Each question has only ONE correct answer. Write only the letter (A–D) next to the question number (2.1–2.10) in the ANSWER BOOK.

- 2.1 Which ONE of the following compounds has the highest melting point?
- A CH_3CH_3
- B $\text{CH}_3\text{CH}_2\text{CH}_3$
- C $\text{CH}_3\text{CH}_2\text{CH}_2\text{CH}_3$
- D $\text{CH}_3\text{CH}_2\text{CH}_2\text{CH}_2\text{CH}_3$ (2)
- 2.2 Consider the organic compounds (I to IV) shown below.

| | | | |
|------------|---|-----------|--|
| I | $\text{CH} \equiv \text{C} - \text{CH}_2 - \text{CH}_3$ | II | $\text{CH}_3 - \text{C} \equiv \text{C} - \text{CH}_2 - \text{CH}_3$ |
| III | $\text{CH}_3 - \text{C} \equiv \text{C} - \text{CH}_3$ | IV | $\text{CH}_3 - \text{C} \equiv \text{CH}$ |

Which of the compounds above are structural isomers?

- A I and II
- B I and III
- C I and IV
- D II and III (2)

2.3 Consider the reaction represented below.

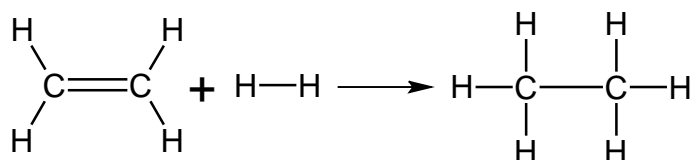

This reaction is an example of ...

- A addition.
- B oxidation.
- C elimination.
- D substitution. (2)

2.4 Activation energy can best be described as the minimum energy required to ...

- A cause effective collisions.
- B make reactant molecules collide.
- C increase the kinetic energy of reactant molecules.
- D change the orientation of reactant molecules. (2)

2.5 Which ONE of the following CORRECTLY describes the effect of an INCREASE IN TEMPERATURE on a reaction at equilibrium?

| | Reaction favoured | Reaction rate |
|---|-------------------|---------------|
| A | Exothermic | Increases |
| B | Exothermic | Decreases |
| C | Endothermic | Increases |
| D | Endothermic | Decreases |

(2)

2.6 Each of the reactions represented below is at equilibrium in a closed container. In which ONE of these reactions will an INCREASE IN PRESSURE (by decreasing the volume) favour the formation of products?

- A $\text{N}_2\text{O}_4(\text{g}) \rightleftharpoons 2\text{NO}_2(\text{g})$
- B $\text{PCl}_5(\text{g}) \rightleftharpoons \text{PCl}_3(\text{g}) + \text{Cl}_2(\text{g})$
- C $\text{N}_2(\text{g}) + 3\text{H}_2(\text{g}) \rightleftharpoons 2\text{NH}_3(\text{g})$
- D $\text{NO}_2(\text{g}) + \text{CO}(\text{g}) \rightleftharpoons \text{NO}(\text{g}) + \text{CO}_2(\text{g})$ (2)

2.7 Which ONE of the following half-reactions occurs at the CATHODE during the electrolysis of a solution of CuCl_2 ?

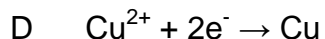
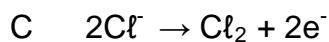
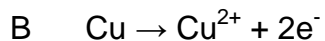
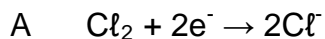

(2)

2.8 When a galvanic (voltaic) cell delivers current, the salt bridge ...

A allows electrons to move in the cell.

B ensures electrical neutrality in the cell.

C prevents the two solutions from mixing.

D allows electrons to travel from the cathode to the anode.

(2)

2.9 Which ONE of the following metals is the strongest reducing agent?

A Ag

B Zn

C Cu

D Al

(2)

2.10 The chlor-alkali process leads to the production of two gases. Which ONE of the following CORRECTLY shows the gases produced at the anode and cathode of this cell?

| | Anode | Cathode |
|---|--------------|--------------|
| A | Oxygen gas | Chlorine gas |
| B | Hydrogen gas | Chlorine gas |
| C | Chlorine gas | Hydrogen gas |
| D | Chlorine gas | Water vapour |

(2)

[20]**TOTAL SECTION A: 25**

SECTION B**INSTRUCTIONS**

1. Start EACH question on a NEW page.
2. Leave ONE line between two subquestions, for example between QUESTION 3.1 and QUESTION 3.2.
3. Show the formulae and substitutions in ALL calculations.
4. Round off your final numerical answers to a minimum of TWO decimal places.

QUESTION 3 (Start on a new page.)

The letters **A** to **F** in the table below represent six organic compounds.

| | | | |
|----------|--|----------|--|
| A | Pent-2-ene | B | <pre> H H H H — C — C — C — O — H H H H — C — H H </pre> |
| C | Propyl methanoate | D | 2,5-dimethylheptane |
| E | $\text{CH}_3 - \underset{\text{CH}_3}{\text{CH}} - \text{CH}_2 - \overset{\text{O}}{\parallel}{\text{C}} - \text{H}$ | F | $\text{CH}_3 - \text{CH}_2 - \text{CH}_2 - \overset{\text{O}}{\parallel}{\text{C}} - \text{CH}_3$ |

- 3.1 Write down the letter representing the compound which:
(A compound may be used more than once.)
- 3.1.1 Is an aldehyde (1)
 - 3.1.2 Has the general formula C_nH_{2n} (1)
 - 3.1.3 Is unsaturated (1)
 - 3.1.4 Is a ketone (1)
 - 3.1.5 Is a hydrocarbon (1)
 - 3.1.6 Can be prepared by the reaction of an alcohol with a carboxylic acid (1)

- 3.2 Write down the structural formula of:
- 3.2.1 Compound **A** (2)
- 3.2.2 Compound **D** (2)
- 3.3 Write down the:
- 3.3.1 NAME of the functional group of compound **F** (1)
- 3.3.2 IUPAC name of compound **B** (2)
- [13]

QUESTION 4 (Start on a new page.)

The table below shows the boiling points of four organic compounds, represented by the letters **A** to **D**, of comparable molecular mass.

| | Compound | Molecular mass | Boiling point (°C) |
|----------|---------------|----------------|--------------------|
| A | Butane | 58 | 0 |
| B | Propanal | 58 | 49 |
| C | Propan-1-ol | 60 | 97 |
| D | Ethanoic acid | 60 | 118 |

- 4.1 Compound **A** is used as a fuel in gas burners.
- 4.1.1 Is compound **A** in the GAS, LIQUID or SOLID phase at 25 °C? (1)
- 4.1.2 How will the boiling point of an ISOMER of compound **A** compare to that of compound **A**? Write down HIGHER THAN, LOWER THAN or EQUAL TO. Refer to MOLECULAR STRUCTURE, INTERMOLECULAR FORCES and the ENERGY needed to explain the answer. (4)
- 4.1.3 Using molecular formulae, write down the balanced equation for the combustion of compound **A** in excess oxygen. (3)
- 4.1.4 Compound **A** has a lower boiling point than compound **B**. Give reasons for this difference in boiling points by referring to the following: (2)
- Structural differences between the two compounds
 - Polarity
- 4.2 Consider the boiling points of compounds **C** and **D**.
- 4.2.1 Give a reason for this difference in boiling points by referring to the intermolecular forces present in EACH of these compounds. (2)
- 4.2.2 Which ONE of compound **C** or **D** has a higher vapour pressure? Refer to their boiling points to give a reason for the answer. (2)
- [14]

QUESTION 5 (Start on a new page.)

Some of the reactions of BUTAN-1-OL are represented in the flow diagram below. **P**, **Q** and **R** represent the organic products formed.

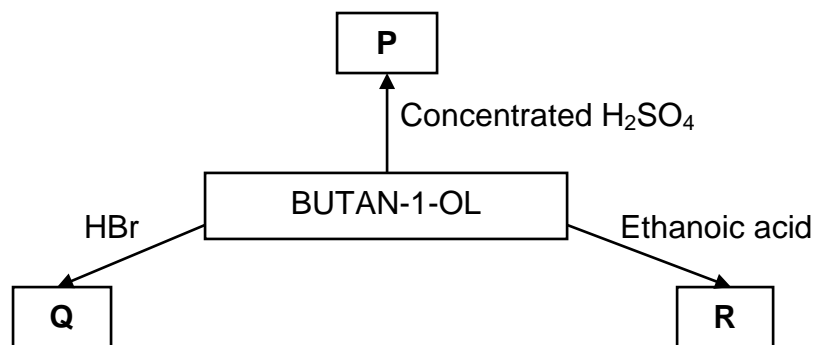

5.1 Is butan-1-ol a PRIMARY, SECONDARY or TERTIARY alcohol? (1)

5.2 Product **P** is formed when butan-1-ol is heated in the presence of concentrated sulphuric acid.

Write down the:

5.2.1 Name of the type of reaction that takes place (1)

5.2.2 Balanced equation for the reaction that takes place using structural formulae (5)

5.3 Product **R** is formed when butan-1-ol reacts with ethanoic acid in the presence of an acid catalyst.

Write down the:

5.3.1 Name of the type of reaction that takes place (1)

5.3.2 Structural formula of the organic product formed (2)

5.4 When HBr reacts with butan-1-ol, compound **Q**, a haloalkane, is formed.

Write down the:

5.4.1 Name of the type of reaction that takes place (1)

5.4.2 IUPAC name of the haloalkane formed (2)

[13]

QUESTION 6 (Start on a new page.)

The apparatus shown below is used to investigate the rate at which hydrogen gas is produced when a certain amount of zinc reacts with an excess of a dilute hydrochloric acid solution.

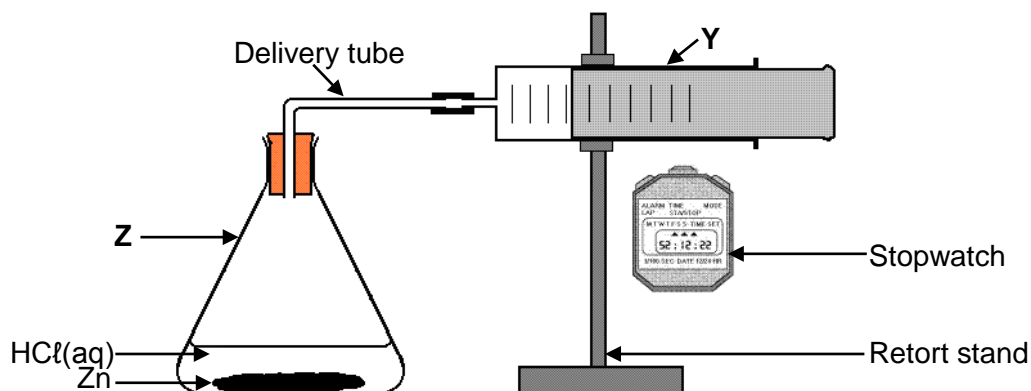

The reaction that takes place is represented by the following balanced equation:

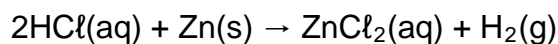

- 6.1 Write down the name of the flask labelled **Z**. (1)
- 6.2 Write down ONE function of the item of apparatus labelled **Y** in THIS investigation. (1)

Two experiments are conducted using the apparatus above. The conditions for each experiment are given in the table below.

| | Experiment 1 | Experiment 2 |
|-------------------|--------------------------|--------------------------|
| Zinc | powdered | powdered |
| Hydrochloric acid | 0,1 mol·dm ⁻³ | 0,2 mol·dm ⁻³ |
| Temperature | 25 °C | 25 °C |

- 6.3 FROM THE TABLE ABOVE, write down:
- 6.3.1 The independent variable for this investigation (1)
- 6.3.2 ONE controlled variable (1)

The volume of hydrogen gas produced is measured in each experiment. The graphs below show the results obtained.

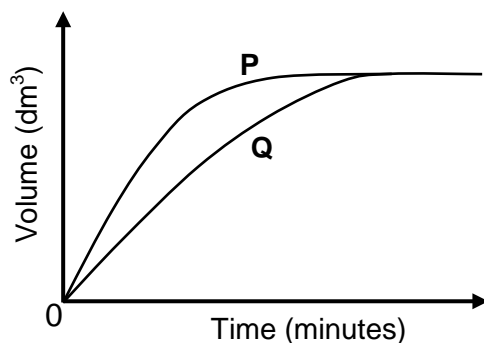

- 6.4 Which graph, **P** or **Q**, represents Experiment 2? Refer to the data given in the table, as well as the shape of the graph, to explain how you arrived at the answer. (3)
- 6.5 Give a reason why the rate of hydrogen production slows down towards the end in both experiments. (1)
- 6.6 Calculate the mass of zinc used to prepare $0,24 \text{ dm}^3$ of hydrogen gas at room temperature. Assume that 1 mole of hydrogen gas has a volume of $24,04 \text{ dm}^3$ at room temperature. (6)

[14]

QUESTION 7 (Start on a new page.)

The reaction between hydrogen chloride and oxygen reaches equilibrium in a closed container according to the following balanced equation:

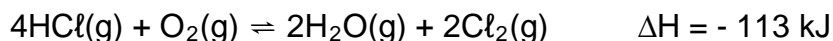

- 7.1 Is this reaction exothermic or endothermic? Give a reason for the answer. (2)
- 7.2 The graphs below, not drawn to scale, show how the amounts of reactants present in the container change with time at a specific temperature. The volume of the container is 5 dm^3 .

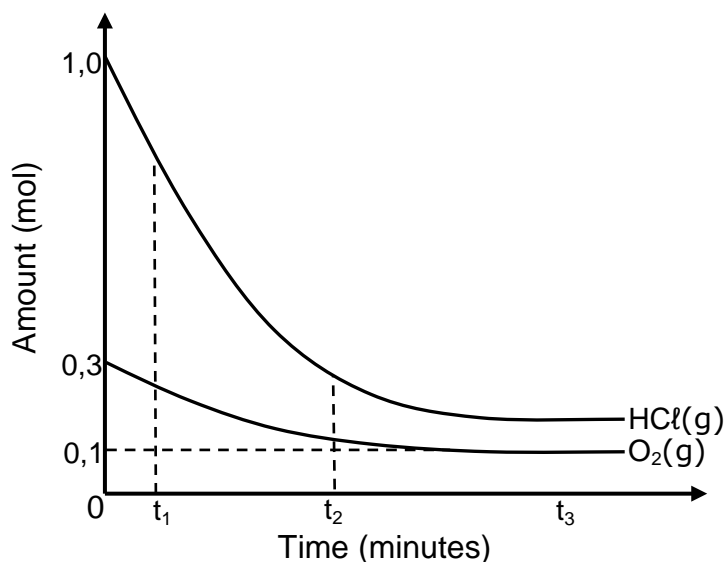

- 7.2.1 How does the rate of the forward reaction at time t_1 compare to that at time t_2 ? Write down GREATER THAN, SMALLER THAN or EQUAL TO. Use the graphs to give a reason for the answer. (2)
- 7.2.2 How does the rate of the forward and the reverse reactions compare at time t_3 ? Write down only GREATER THAN, SMALLER THAN or EQUAL TO. (1)
- 7.2.3 Calculate the equilibrium constant (K_c) for this reaction at this temperature. (9)
- 7.3 The temperature is NOW increased. How will this change affect the value of the equilibrium constant?
Write down INCREASES, DECREASES or REMAINS THE SAME. Explain the answer. (4)
- 7.4 How will each of the following changes affect the equilibrium concentration of $\text{Cl}_2(\text{g})$? Write down INCREASES, DECREASES or REMAINS THE SAME.
- 7.4.1 Water vapour is added into the container. (1)
- 7.4.2 A catalyst is added. (1)
- 7.4.3 The volume of the container is increased. (1)

[21]

QUESTION 8 (Start on a new page.)

The electrochemical cell represented below consists of a hydrogen half-cell and a magnesium half-cell at standard conditions.

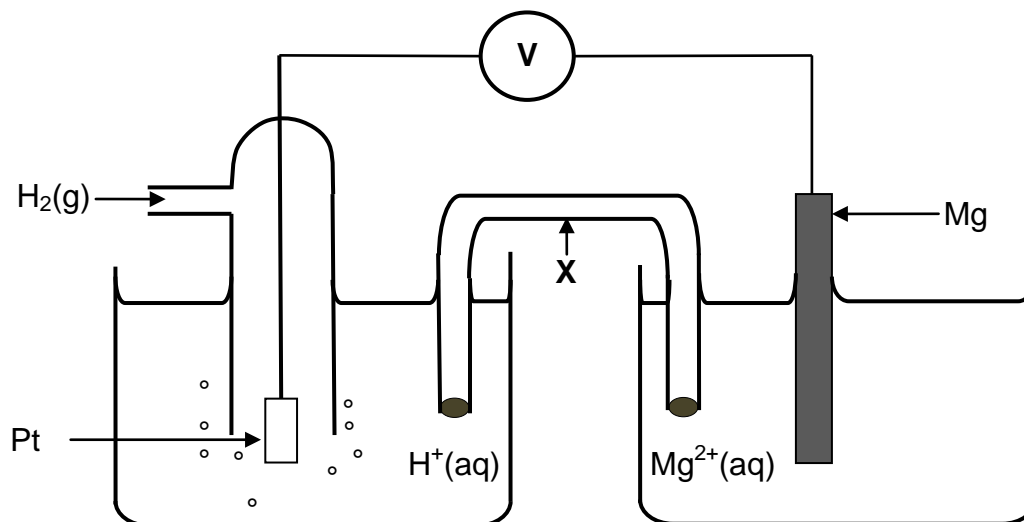

The reading on the voltmeter is 2,36 V.

- 8.1 Apart from concentration, write down TWO other conditions needed for the hydrogen half-cell to function at standard conditions. (2)
- 8.2 Write down the name of the item of apparatus labelled **X**. (1)
- 8.3 Is magnesium the ANODE or CATHODE in the cell above? Refer to the relative strengths of reducing agents to explain the answer. (4)
- 8.4 Write down the cell notation for this cell. (3)
- 8.5 Calculate the standard reduction potential of the magnesium half-cell. Show ALL your working. (4)
- 8.6 Write down the balanced NET (overall) cell reaction that takes place in this cell. No spectator ions are required. (3)

[17]

QUESTION 9 (Start on a new page.)

The simplified diagrams below represent two electrochemical cells, **A** and **B**, used in INDUSTRY. Cell **A** is used in the purification of copper ore containing silver and platinum impurities. Cell **B** is used to electroplate a bracelet with a layer of copper.

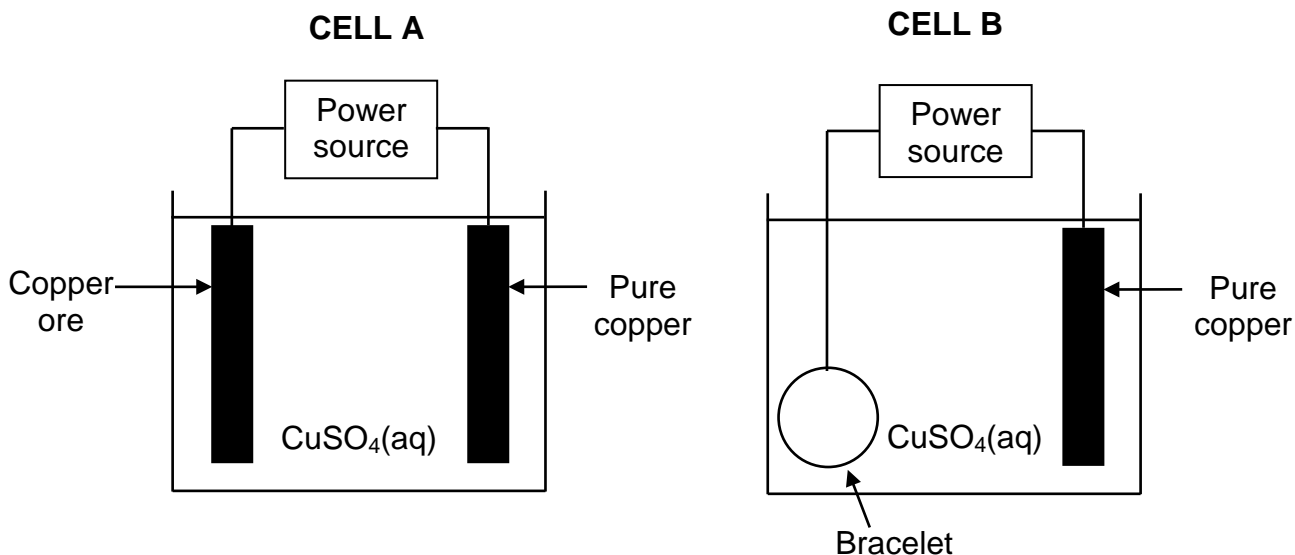

- 9.1 Write down the name of the type of electrochemical cell (ELECTROLYTIC or GALVANIC) of which the above two cells are examples. (1)
- 9.2 Pure copper is used as one of the electrodes in each of the cells above. In which cell (**A** or **B**) is the pure copper the:
- 9.2.1 Cathode (1)
- 9.2.2 Anode (1)
- 9.3 Consider cell **B**. Initially the $\text{CuSO}_4(\text{aq})$ has a blue colour.
- 9.3.1 How will the intensity of the blue colour change whilst the cell is functioning? Write down INCREASES, DECREASES or REMAINS THE SAME. Give a reason for the answer. (3)
- 9.3.2 Write down the half-reaction that takes place at the pure copper electrode. (2)
- 9.4 Consider cell **A**.
- 9.4.1 Give a reason why the sludge formed in this cell is of economic importance. (1)
- 9.4.2 Name ONE negative impact that the energy usage in this process has on the environment. (2)

[11]

QUESTION 10 (Start on a new page.)

Nickel-zinc cells are rechargeable. The half-reactions that take place in such cells are:

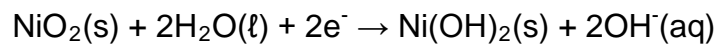
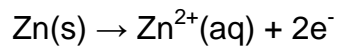

- 10.1 Write down the general name given to cells that are rechargeable. (1)
- 10.2 Write down the balanced net (overall) cell reaction that takes place in this cell. (3)
- 10.3 The emf of one such cell is 1,65 V and its capacity is 1 500 mA·h.
- 10.3.1 Define the term *cell capacity*. (2)
- 10.3.2 Calculate the maximum electrical work that can be done by this cell. (4)
- [10]**

QUESTION 11 (Start on a new page.)

Different processes used in the preparation of fertilisers **C** and **F** are represented in the flow diagram below.

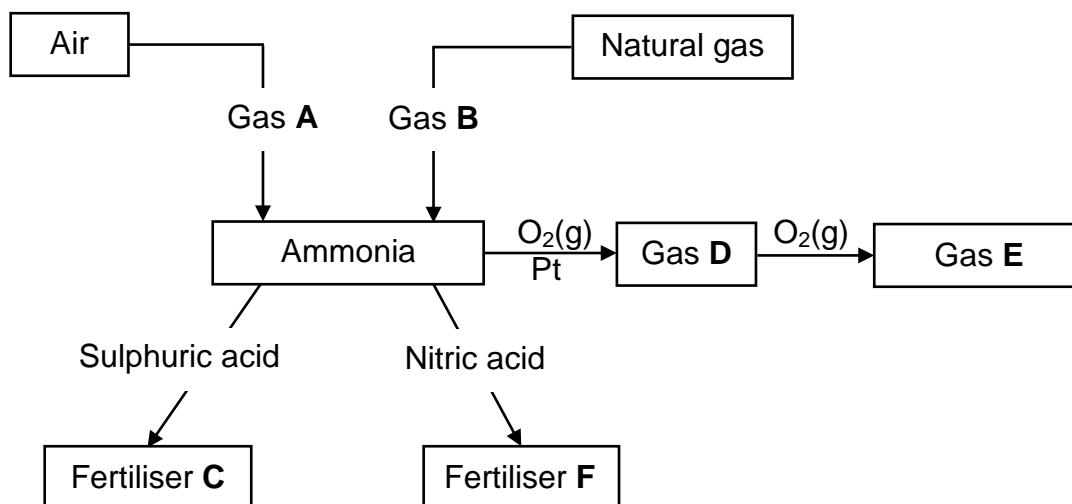

11.1 Write down the NAME or FORMULA of:

11.1.1 Gas **A** (1)

11.1.2 Gas **B** (1)

11.1.3 Fertiliser **F** (1)

11.2 Sulphuric acid is used to prepare fertiliser **C**.

Write down:

11.2.1 The name of the industrial process used to prepare sulphuric acid (1)

11.2.2 A balanced equation for the preparation of fertiliser **C** (3)

11.3 Gases **D** and **E** are prepared during the Ostwald process.

Write down the:

11.3.1 Name given to the preparation of gas **D** from ammonia (1)

11.3.2 Balanced equation for the preparation of gas **D** (3)

11.3.3 NAME or FORMULA of gas **E** (1)

[12]

TOTAL SECTION B: 125
GRAND TOTAL: 150

**DATA FOR PHYSICAL SCIENCES GRADE 12
PAPER 2 (CHEMISTRY)**

**GEGEWENS VIR FISIESTE WETENSAPPE GRAAD 12
VRAESTEL 2 (CHEMIE)**

TABLE 1: PHYSICAL CONSTANTS/TABEL 1: FISIESTE KONSTANTES

| NAME/NAAM | SYMBOL/SIMBOOL | VALUE/WAARDE |
|---|----------------|---|
| Standard pressure <i>Standaarddruk</i> | p^θ | $1,013 \times 10^5 \text{ Pa}$ |
| Molar gas volume at STP <i>Molêre gasvolume by STD</i> | V_m | $22,4 \text{ dm}^3 \cdot \text{mol}^{-1}$ |
| Standard temperature <i>Standaardtemperatuur</i> | T^θ | 273 K |
| Charge on electron <i>Lading op elektron</i> | e | $-1,6 \times 10^{-19} \text{ C}$ |

TABLE 2: FORMULAE/TABEL 2: FORMULES

| | |
|------------------------------|---|
| $n = \frac{m}{M}$ | $c = \frac{n}{V}$ or/of $c = \frac{m}{MV}$ |
| $q = I \Delta t$ $W = Vq$ | $E_{\text{cell}}^\theta = E_{\text{cathode}}^\theta - E_{\text{anode}}^\theta / E_{\text{sel}}^\theta = E_{\text{katode}}^\theta - E_{\text{anode}}^\theta$ or/of $E_{\text{cell}}^\theta = E_{\text{reduction}}^\theta - E_{\text{oxidation}}^\theta / E_{\text{sel}}^\theta = E_{\text{reduksie}}^\theta - E_{\text{oksidasie}}^\theta$ or/of $E_{\text{cell}}^\theta = E_{\text{oxidising agent}}^\theta - E_{\text{reducing agent}}^\theta / E_{\text{sel}}^\theta = E_{\text{oksideermiddel}}^\theta - E_{\text{reduseermiddel}}^\theta$ |

TABLE 4A: STANDARD REDUCTION POTENTIALS
TABEL 4A: STANDAARD-REDUKSIEPOTENSIALE

| Half-reactions/ <i>Halfreaksies</i> | E^{\ominus} (V) |
|---|-------------------|
| $F_2(g) + 2e^- \rightleftharpoons 2F^-$ | + 2,87 |
| $Co^{3+} + e^- \rightleftharpoons Co^{2+}$ | + 1,81 |
| $H_2O_2 + 2H^+ + 2e^- \rightleftharpoons 2H_2O$ | +1,77 |
| $MnO_4^- + 8H^+ + 5e^- \rightleftharpoons Mn^{2+} + 4H_2O$ | + 1,51 |
| $Cl_2(g) + 2e^- \rightleftharpoons 2Cl^-$ | + 1,36 |
| $Cr_2O_7^{2-} + 14H^+ + 6e^- \rightleftharpoons 2Cr^{3+} + 7H_2O$ | + 1,33 |
| $O_2(g) + 4H^+ + 4e^- \rightleftharpoons 2H_2O$ | + 1,23 |
| $MnO_2 + 4H^+ + 2e^- \rightleftharpoons Mn^{2+} + 2H_2O$ | + 1,23 |
| $Pt^{2+} + 2e^- \rightleftharpoons Pt$ | + 1,20 |
| $Br_2(l) + 2e^- \rightleftharpoons 2Br^-$ | + 1,07 |
| $NO_3^- + 4H^+ + 3e^- \rightleftharpoons NO(g) + 2H_2O$ | + 0,96 |
| $Hg^{2+} + 2e^- \rightleftharpoons Hg(l)$ | + 0,85 |
| $Ag^+ + e^- \rightleftharpoons Ag$ | + 0,80 |
| $NO_3^- + 2H^+ + e^- \rightleftharpoons NO_2(g) + H_2O$ | + 0,80 |
| $Fe^{3+} + e^- \rightleftharpoons Fe^{2+}$ | + 0,77 |
| $O_2(g) + 2H^+ + 2e^- \rightleftharpoons H_2O_2$ | + 0,68 |
| $I_2 + 2e^- \rightleftharpoons 2I^-$ | + 0,54 |
| $Cu^+ + e^- \rightleftharpoons Cu$ | + 0,52 |
| $SO_2 + 4H^+ + 4e^- \rightleftharpoons S + 2H_2O$ | + 0,45 |
| $2H_2O + O_2 + 4e^- \rightleftharpoons 4OH^-$ | + 0,40 |
| $Cu^{2+} + 2e^- \rightleftharpoons Cu$ | + 0,34 |
| $SO_4^{2-} + 4H^+ + 2e^- \rightleftharpoons SO_2(g) + 2H_2O$ | + 0,17 |
| $Cu^{2+} + e^- \rightleftharpoons Cu^+$ | + 0,16 |
| $Sn^{4+} + 2e^- \rightleftharpoons Sn^{2+}$ | + 0,15 |
| $S + 2H^+ + 2e^- \rightleftharpoons H_2S(g)$ | + 0,14 |
| $2H^+ + 2e^- \rightleftharpoons H_2(g)$ | 0,00 |
| $Fe^{3+} + 3e^- \rightleftharpoons Fe$ | - 0,06 |
| $Pb^{2+} + 2e^- \rightleftharpoons Pb$ | - 0,13 |
| $Sn^{2+} + 2e^- \rightleftharpoons Sn$ | - 0,14 |
| $Ni^{2+} + 2e^- \rightleftharpoons Ni$ | - 0,27 |
| $Co^{2+} + 2e^- \rightleftharpoons Co$ | - 0,28 |
| $Cd^{2+} + 2e^- \rightleftharpoons Cd$ | - 0,40 |
| $Cr^{3+} + e^- \rightleftharpoons Cr^{2+}$ | - 0,41 |
| $Fe^{2+} + 2e^- \rightleftharpoons Fe$ | - 0,44 |
| $Cr^{3+} + 3e^- \rightleftharpoons Cr$ | - 0,74 |
| $Zn^{2+} + 2e^- \rightleftharpoons Zn$ | - 0,76 |
| $2H_2O + 2e^- \rightleftharpoons H_2(g) + 2OH^-$ | - 0,83 |
| $Cr^{2+} + 2e^- \rightleftharpoons Cr$ | - 0,91 |
| $Mn^{2+} + 2e^- \rightleftharpoons Mn$ | - 1,18 |
| $Al^{3+} + 3e^- \rightleftharpoons Al$ | - 1,66 |
| $Mg^{2+} + 2e^- \rightleftharpoons Mg$ | - 2,36 |
| $Na^+ + e^- \rightleftharpoons Na$ | - 2,71 |
| $Ca^{2+} + 2e^- \rightleftharpoons Ca$ | - 2,87 |
| $Sr^{2+} + 2e^- \rightleftharpoons Sr$ | - 2,89 |
| $Ba^{2+} + 2e^- \rightleftharpoons Ba$ | - 2,90 |
| $Cs^+ + e^- \rightleftharpoons Cs$ | - 2,92 |
| $K^+ + e^- \rightleftharpoons K$ | - 2,93 |
| $Li^+ + e^- \rightleftharpoons Li$ | - 3,05 |

Increasing oxidising ability/*Toenemende oksiderende vermoë*

Increasing reducing ability/*Toenemende reducerende vermoë*

TABLE 4B: STANDARD REDUCTION POTENTIALS
TABEL 4B: STANDAARD-REDUKSIEPOTENSIALE

| Half-reactions/ <i>Halfreaksies</i> | E^{\ominus} (V) |
|---|-------------------|
| $\text{Li}^+ + e^- \rightleftharpoons \text{Li}$ | - 3,05 |
| $\text{K}^+ + e^- \rightleftharpoons \text{K}$ | - 2,93 |
| $\text{Cs}^+ + e^- \rightleftharpoons \text{Cs}$ | - 2,92 |
| $\text{Ba}^{2+} + 2e^- \rightleftharpoons \text{Ba}$ | - 2,90 |
| $\text{Sr}^{2+} + 2e^- \rightleftharpoons \text{Sr}$ | - 2,89 |
| $\text{Ca}^{2+} + 2e^- \rightleftharpoons \text{Ca}$ | - 2,87 |
| $\text{Na}^+ + e^- \rightleftharpoons \text{Na}$ | - 2,71 |
| $\text{Mg}^{2+} + 2e^- \rightleftharpoons \text{Mg}$ | - 2,36 |
| $\text{Al}^{3+} + 3e^- \rightleftharpoons \text{Al}$ | - 1,66 |
| $\text{Mn}^{2+} + 2e^- \rightleftharpoons \text{Mn}$ | - 1,18 |
| $\text{Cr}^{2+} + 2e^- \rightleftharpoons \text{Cr}$ | - 0,91 |
| $2\text{H}_2\text{O} + 2e^- \rightleftharpoons \text{H}_2(\text{g}) + 2\text{OH}^-$ | - 0,83 |
| $\text{Zn}^{2+} + 2e^- \rightleftharpoons \text{Zn}$ | - 0,76 |
| $\text{Cr}^{3+} + 3e^- \rightleftharpoons \text{Cr}$ | - 0,74 |
| $\text{Fe}^{2+} + 2e^- \rightleftharpoons \text{Fe}$ | - 0,44 |
| $\text{Cr}^{3+} + e^- \rightleftharpoons \text{Cr}^{2+}$ | - 0,41 |
| $\text{Cd}^{2+} + 2e^- \rightleftharpoons \text{Cd}$ | - 0,40 |
| $\text{Co}^{2+} + 2e^- \rightleftharpoons \text{Co}$ | - 0,28 |
| $\text{Ni}^{2+} + 2e^- \rightleftharpoons \text{Ni}$ | - 0,27 |
| $\text{Sn}^{2+} + 2e^- \rightleftharpoons \text{Sn}$ | - 0,14 |
| $\text{Pb}^{2+} + 2e^- \rightleftharpoons \text{Pb}$ | - 0,13 |
| $\text{Fe}^{3+} + 3e^- \rightleftharpoons \text{Fe}$ | - 0,06 |
| $2\text{H}^+ + 2e^- \rightleftharpoons \text{H}_2(\text{g})$ | 0,00 |
| $\text{S} + 2\text{H}^+ + 2e^- \rightleftharpoons \text{H}_2\text{S}(\text{g})$ | + 0,14 |
| $\text{Sn}^{4+} + 2e^- \rightleftharpoons \text{Sn}^{2+}$ | + 0,15 |
| $\text{Cu}^{2+} + e^- \rightleftharpoons \text{Cu}^+$ | + 0,16 |
| $\text{SO}_4^{2-} + 4\text{H}^+ + 2e^- \rightleftharpoons \text{SO}_2(\text{g}) + 2\text{H}_2\text{O}$ | + 0,17 |
| $\text{Cu}^{2+} + 2e^- \rightleftharpoons \text{Cu}$ | + 0,34 |
| $2\text{H}_2\text{O} + \text{O}_2 + 4e^- \rightleftharpoons 4\text{OH}^-$ | + 0,40 |
| $\text{SO}_2 + 4\text{H}^+ + 4e^- \rightleftharpoons \text{S} + 2\text{H}_2\text{O}$ | + 0,45 |
| $\text{Cu}^+ + e^- \rightleftharpoons \text{Cu}$ | + 0,52 |
| $\text{I}_2 + 2e^- \rightleftharpoons 2\text{I}^-$ | + 0,54 |
| $\text{O}_2(\text{g}) + 2\text{H}^+ + 2e^- \rightleftharpoons \text{H}_2\text{O}_2$ | + 0,68 |
| $\text{Fe}^{3+} + e^- \rightleftharpoons \text{Fe}^{2+}$ | + 0,77 |
| $\text{NO}_3^- + 2\text{H}^+ + e^- \rightleftharpoons \text{NO}_2(\text{g}) + \text{H}_2\text{O}$ | + 0,80 |
| $\text{Ag}^+ + e^- \rightleftharpoons \text{Ag}$ | + 0,80 |
| $\text{Hg}^{2+} + 2e^- \rightleftharpoons \text{Hg}(\ell)$ | + 0,85 |
| $\text{NO}_3^- + 4\text{H}^+ + 3e^- \rightleftharpoons \text{NO}(\text{g}) + 2\text{H}_2\text{O}$ | + 0,96 |
| $\text{Br}_2(\ell) + 2e^- \rightleftharpoons 2\text{Br}^-$ | + 1,07 |
| $\text{Pt}^{2+} + 2e^- \rightleftharpoons \text{Pt}$ | + 1,20 |
| $\text{MnO}_2 + 4\text{H}^+ + 2e^- \rightleftharpoons \text{Mn}^{2+} + 2\text{H}_2\text{O}$ | + 1,23 |
| $\text{O}_2(\text{g}) + 4\text{H}^+ + 4e^- \rightleftharpoons 2\text{H}_2\text{O}$ | + 1,23 |
| $\text{Cr}_2\text{O}_7^{2-} + 14\text{H}^+ + 6e^- \rightleftharpoons 2\text{Cr}^{3+} + 7\text{H}_2\text{O}$ | + 1,33 |
| $\text{Cl}_2(\text{g}) + 2e^- \rightleftharpoons 2\text{Cl}^-$ | + 1,36 |
| $\text{MnO}_4^- + 8\text{H}^+ + 5e^- \rightleftharpoons \text{Mn}^{2+} + 4\text{H}_2\text{O}$ | + 1,51 |
| $\text{H}_2\text{O}_2 + 2\text{H}^+ + 2e^- \rightleftharpoons 2\text{H}_2\text{O}$ | + 1,77 |
| $\text{Co}^{3+} + e^- \rightleftharpoons \text{Co}^{2+}$ | + 1,81 |
| $\text{F}_2(\text{g}) + 2e^- \rightleftharpoons 2\text{F}^-$ | + 2,87 |

Increasing oxidising ability/*Toenemende oksiderende vermoë*

Increasing reducing ability/*Toenemende reduserende vermoë*